

Technical Information

Turbimax CUS52D

Turbidity sensor



Installation and immersion sensor for low to medium turbidity

Application

Turbimax CUS52D is a sensor for all drinking water and process water applications.

- Final turbidity measurement in the outlet of waterworks
- Turbidity measurement in the inlet of waterworks
- Turbidity measurement at all stages of the process
- Turbidity measurement for filter monitoring and filter backwashing
- Turbidity measurement in drinking water networks

Your benefits

- Turbidity measurement in accordance with ISO 7027
- The hygienic design with the 2" clamp means it can be mounted directly in pipes and fits into flow assemblies CUA252 (PE 100) and CUA262 (stainless steel).
- Immersion version can be installed in open channels and basins.
- Replaces CUS31 sensor at existing CUS31 assemblies (E and S).
- Can be used at high temperatures and high pressures.
- Standardized communication (Memosens technology) enables "plug and play".
- Intelligent sensor - all characteristic data and calibration values are stored in the sensor.
- Customer calibrations with 1 to 6 points - can be carried out in the lab or at mounting location.
- Completely safe, as the optical source requires little power to operate.

Function and system design

Measuring principle

The sensor works using the 90° light scattering principle in accordance with ISO 7027 and meets all the requirements of this standard. The ISO 7027 standard is obligatory for turbidity measurements in the drinking water sector.

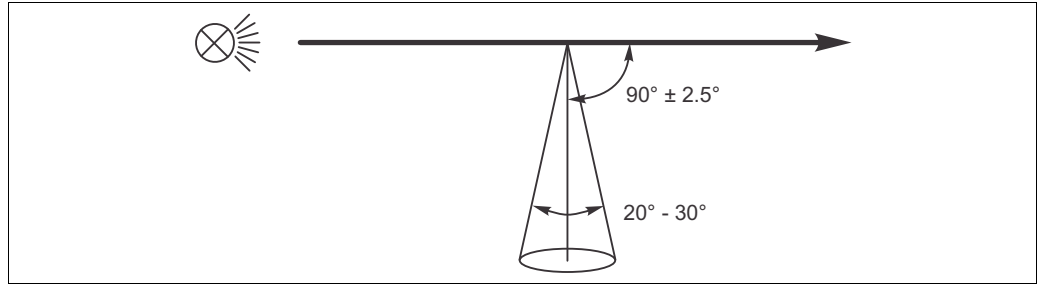

Measurement in accordance with ISO 7027

Measurement is done using a wavelength of 860 nm.

Sensor construction

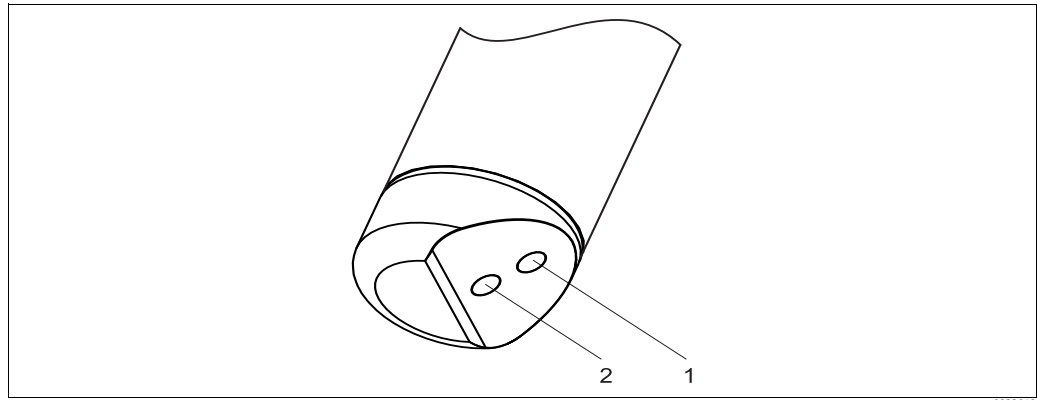

Arrangement of light source and light receiver

- 1 Light receiver
- 2 Light source

Sensor monitoring

The optical signals are continuously monitored and tested for plausibility. In the case of discrepancies, an error message is sent via the transmitter.

Solid state reference

The function and accuracy of the CUS52D sensor can be checked with the Calkit CUS52 solid state references. During factory calibration, every solid state reference is aligned with a special CUS52D sensor and can only be used with this sensor. Therefore the solid state reference and the CUS52D sensor are married (permanently assigned) to one another.

The following solid state references are available:

- 5 FNU (NTU)
- 20 FNU (NTU)
- 50 FNU (NTU)

The reference value indicated on the solid state reference is reproduced with an accuracy of $\pm 10\%$ when the sensor is operating correctly.

Applications

Model name	Application	Unit
Formazin	Drinking water, process water	FNU; NTU; TE/F; EBC; ASBG
Kaolin	Drinking water, filtratable substances, process water	mg/l; g/l; ppm
PSL	The calibration standard commonly used in Japan for drinking water turbidity	度 (dough)
Diatomite	Mineral-based solids (sand)	mg/l; g/l; ppm

Measuring system

A complete measuring system comprises:

- Turbimax CUS52D turbidity sensor
- Liquiline CM44x multi-channel transmitter
- Direct installation in a pipe connection (2" clamp) or assembly:
 - CUA252 flow assembly or
 - CUA262 flow assembly or
 - Flexdip CYA112 assembly and Flexdip CYH112 holder system or
 - Retractable assembly, e.g. Cleanfit CUA451

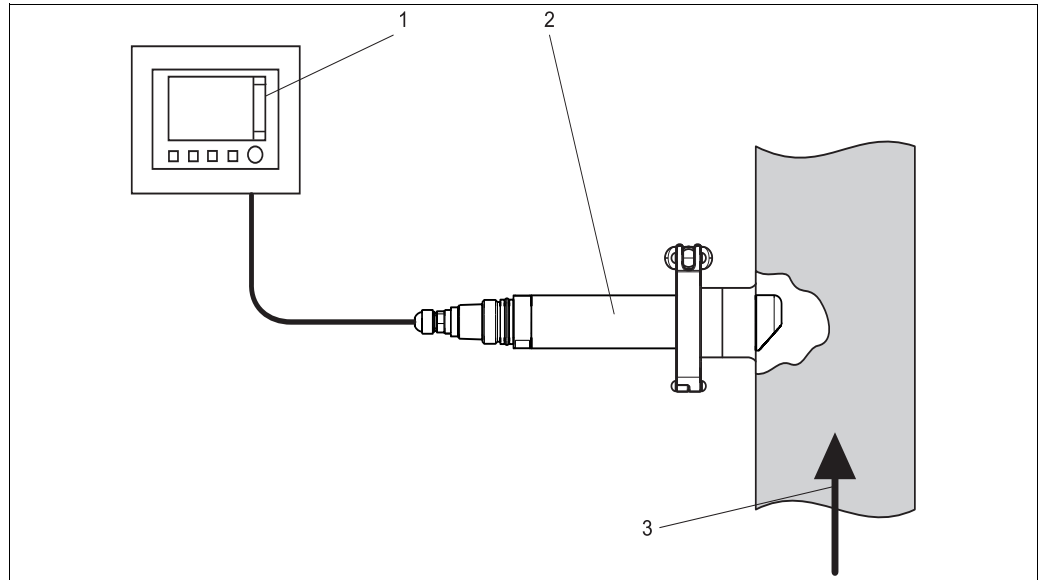

Direct installation in a pipe connection (2" clamp)

- 1 Liquiline CM44x multi-channel transmitter
- 2 Turbimax CUS52D turbidity sensor
- 3 Flow direction

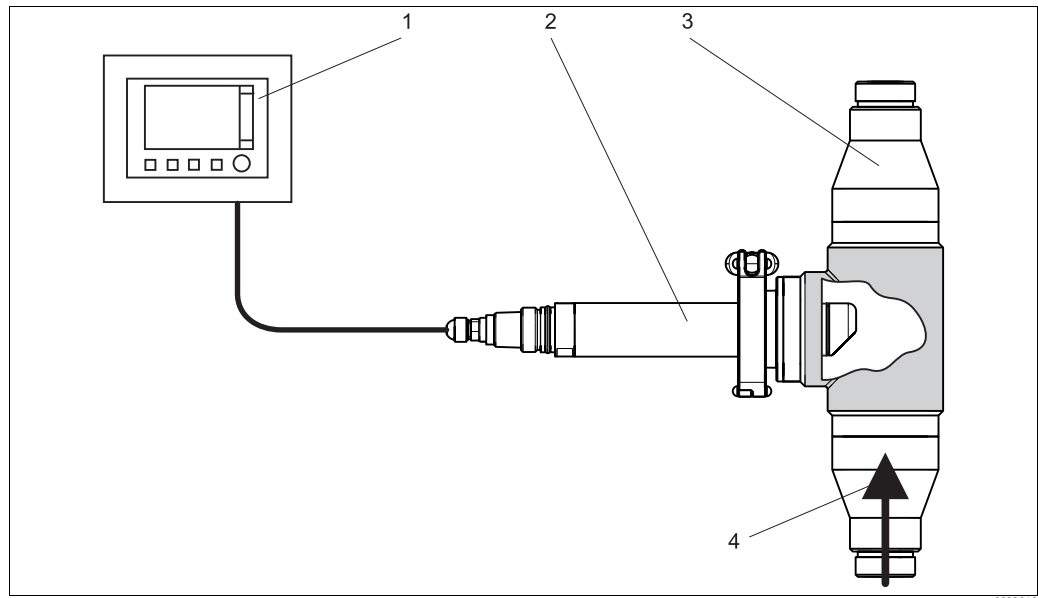

Measuring system with flow assembly CUA252

- 1 Liquiline CM44x multi-channel transmitter
- 2 Turbimax CUS52D turbidity sensor
- 3 CUA252 flow assembly
- 4 Flow direction

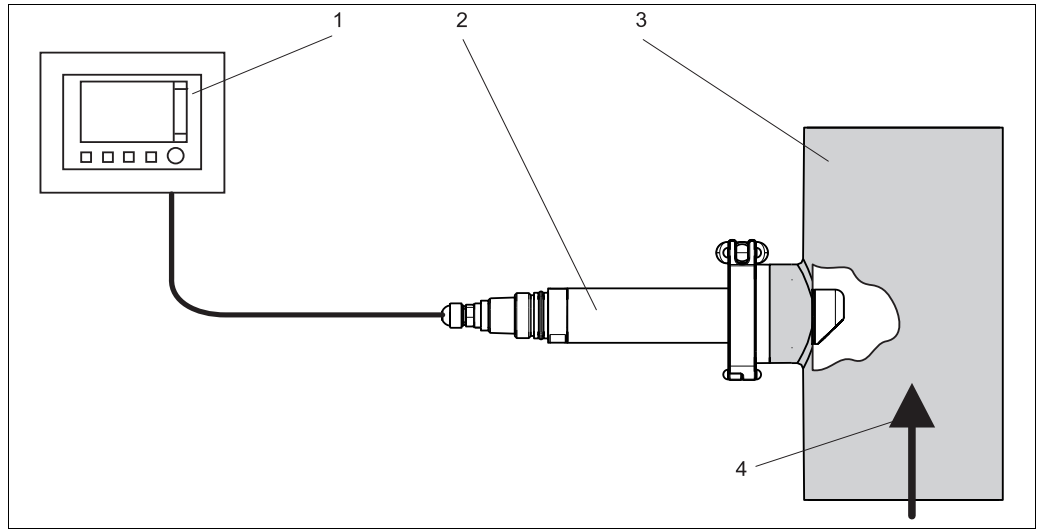

a0022019

Measuring system with flow assembly CUA262

- 1 Liquiline CM44x multi-channel transmitter
- 2 Turbimax CUS52D turbidity sensor
- 3 CUA262 flow assembly
- 4 Flow direction

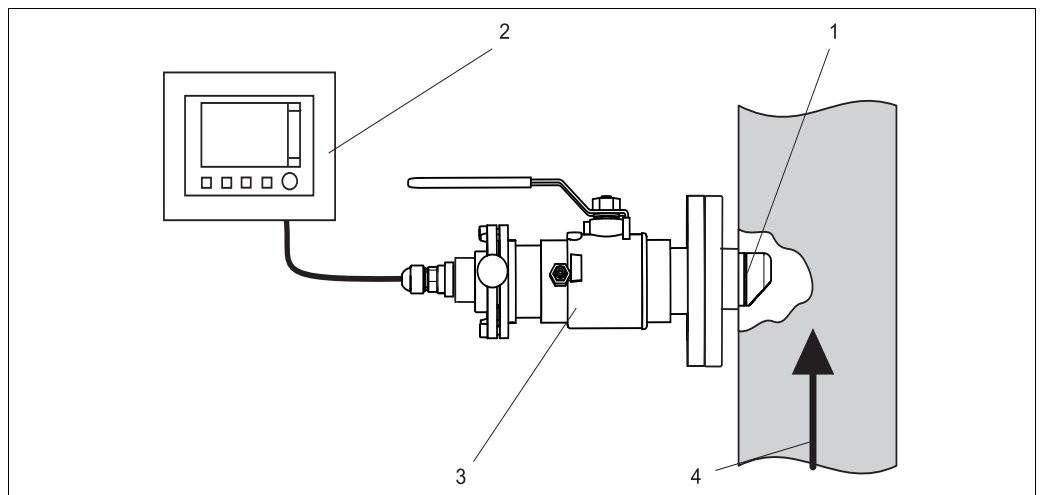

a0022229

Measuring system with retractable assembly

- 1 Turbimax CUS52D turbidity sensor
- 2 Liquiline CM44x multi-channel transmitter
- 3 Cleanfit CUA451 retractable assembly
- 4 Flow direction

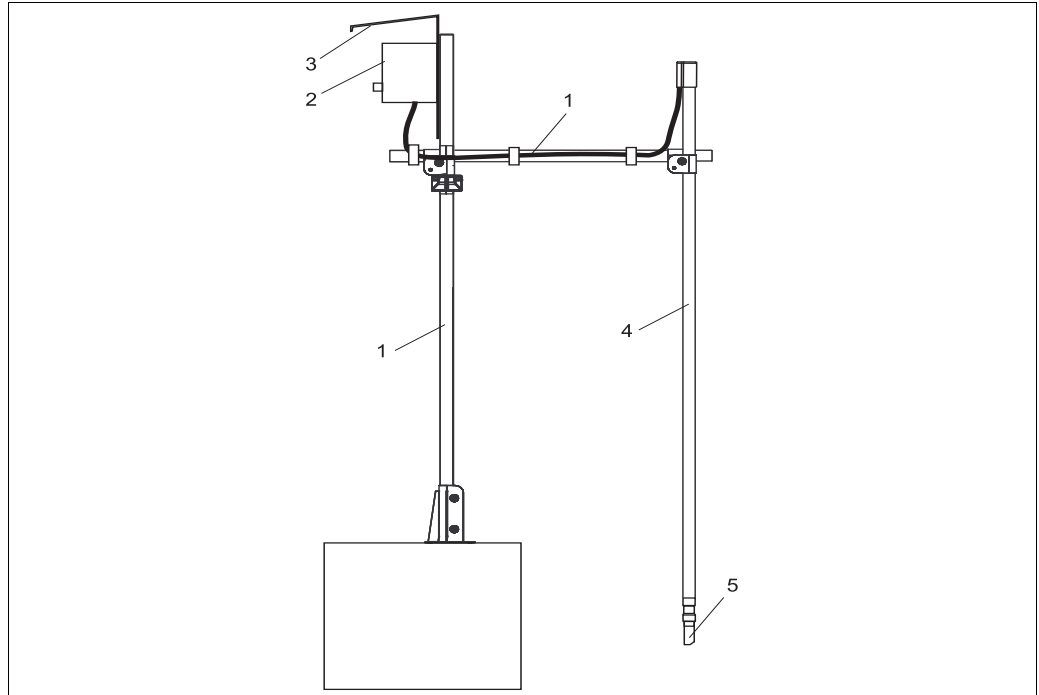

a0022020

Measuring system with immersion assembly

- | | | | |
|---|---|---|----------------------------------|
| 1 | Flexdip CYH112 holder system | 4 | Flexdip CYA112 assembly |
| 2 | Liquiline CM44x multi-channel transmitter | 5 | Turbimax CUS52D turbidity sensor |
| 3 | Weather protection cover | | |

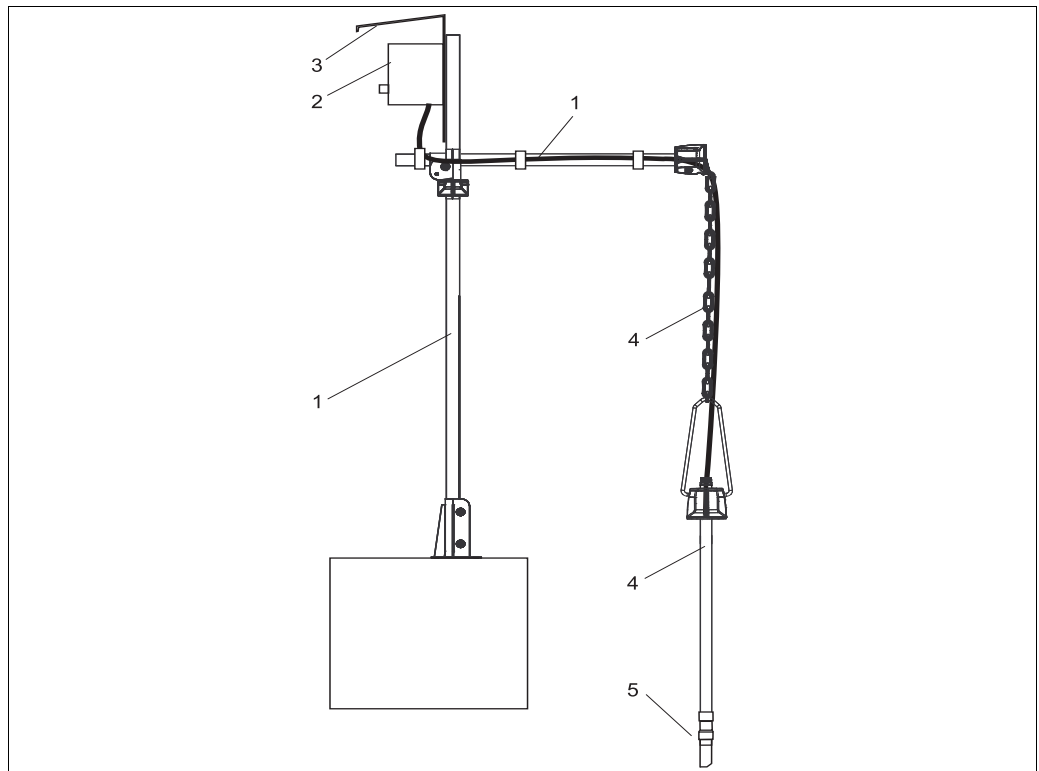

a0022025

Measuring system with immersion assembly on chain holder system

- | | | | |
|---|---|---|----------------------------------|
| 1 | Flexdip CYH112 holder system | 4 | Flexdip CYA112 assembly |
| 2 | Liquiline CM44x multi-channel transmitter | 5 | Turbimax CUS52D turbidity sensor |
| 3 | Weather protection cover | | |

Input

Measured variables	Turbidity Temperature		
Measuring ranges	CUS52D		Application
	Turbidity	0.000 to 4000 FNU Display range to 9999 FNU	Formazin
	Temperature	-20 to +85 °C (-4 to +185 °F)	

For measuring range up to 10 FNU, the sensor exhibits a detection limit (LOD) of 0.0015 FNU (measured in accordance with ISO 15839).

Power supply

Electrical connection

The sensor is connected as follows to the Liquiline CM442 transmitter:

- using the M12 connector (version: fixed cable, M12 connector) or
- using the fixed cable attached to the terminal blocks (version: fixed cable, ferrules):

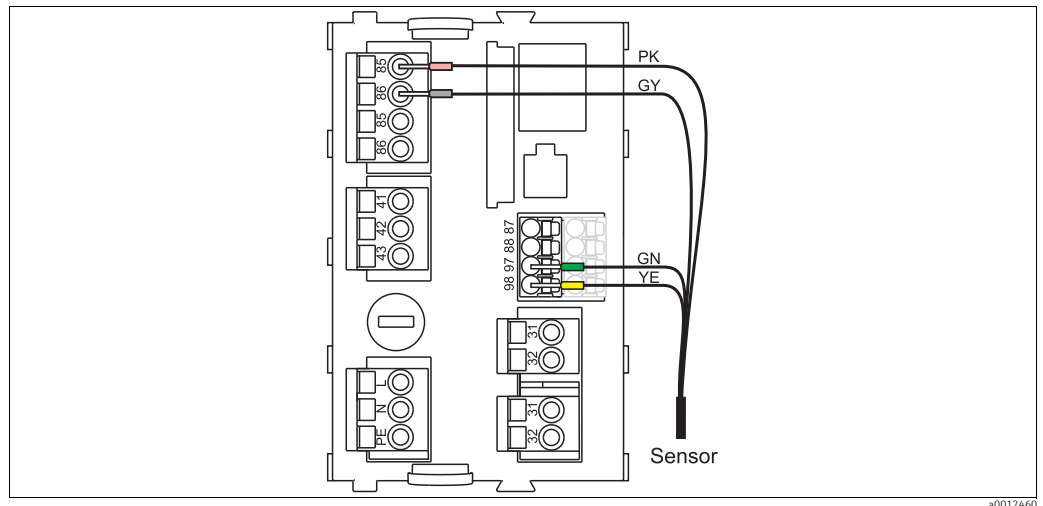

Sensor connection

Maximum cable length is 100 m (328 ft).

Performance characteristics

Measured error 2% ±0.01 FNU; reference: factory calibration

Wavelength 860 nm

Conformity Determining turbidity in accordance with ISO 7027

Factory calibration The sensor has been calibrated in the factory for "formazin" applications.
Basis: internal 20-point characteristic curve

Applications The formazin factory calibration is used as the basis for precalibrating additional applications and optimizing them for the different media characteristics.

Application: water	Recommended operating ranges	Max. display range
Factory calibration for fomazin	0.000 to 4000 FNU	0.000 to 9999 FNU
Application: Kaolin	0 to 600 mg/l	0 to 3 g/l
Application: PSL	0 ... 500 度	0 ... 3000 度
Application: diatomite	0 to 2200 mg/l	0 to 10 g/l

To adapt to a specific application, customer calibrations can be carried out with up to 6 points.

Drift Working on the basis of electronic controls, the sensor is largely free of drifts.

Detection limits

Application	Measuring range	Detection limit
Formazin	0 to 10 FNU (ISO 15839)	0.0015 FNU

Response time >1 sec, adjustable

Repeatability < 0.5 % of measured value (measuring range : 0 to 10 FNU)

Installation

Installation instructions

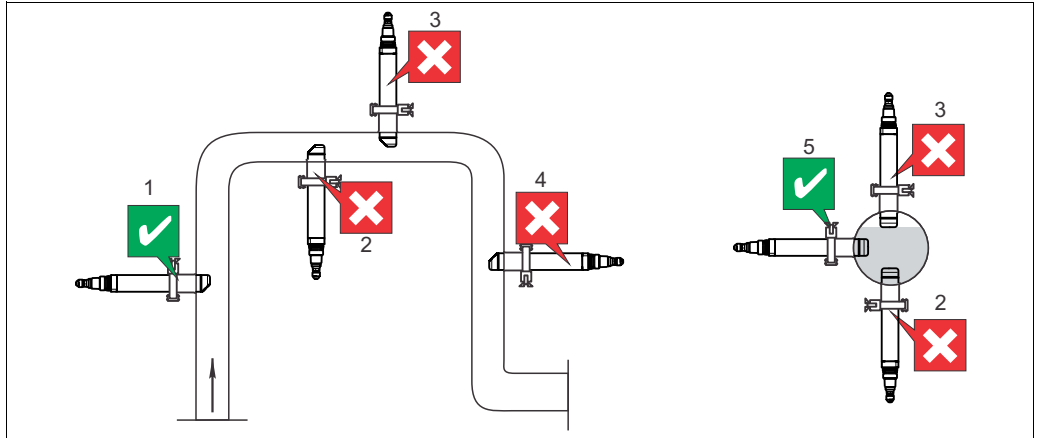

Orientation and positions

- Install the sensor in locations with uniform flow.
- The best installation location is in the ascending pipe (pos. 1). Installation in the horizontal pipe (pos. 5) is also possible.
- Do not install in places where air spaces or bubbles occur (pos. 3) or where sedimentation may occur (pos. 2).
- Installation in the down pipe (pos. 4) should be avoided.
- Avoid fittings downstream from pressure reduction stages, as this may lead to gas emissions.

Wall effects:

Backscattering on the pipe wall may result in the distortion of measurement values in the case of turbidity values < 200 FNU. It is recommended that you adjust the installation. Black plastic pipes with diameter > DN 60 exhibit hardly any wall effects (<0.05 FNU). For this reason, the use of black plastic pipes is recommended.

Additional information on avoiding wall effects:

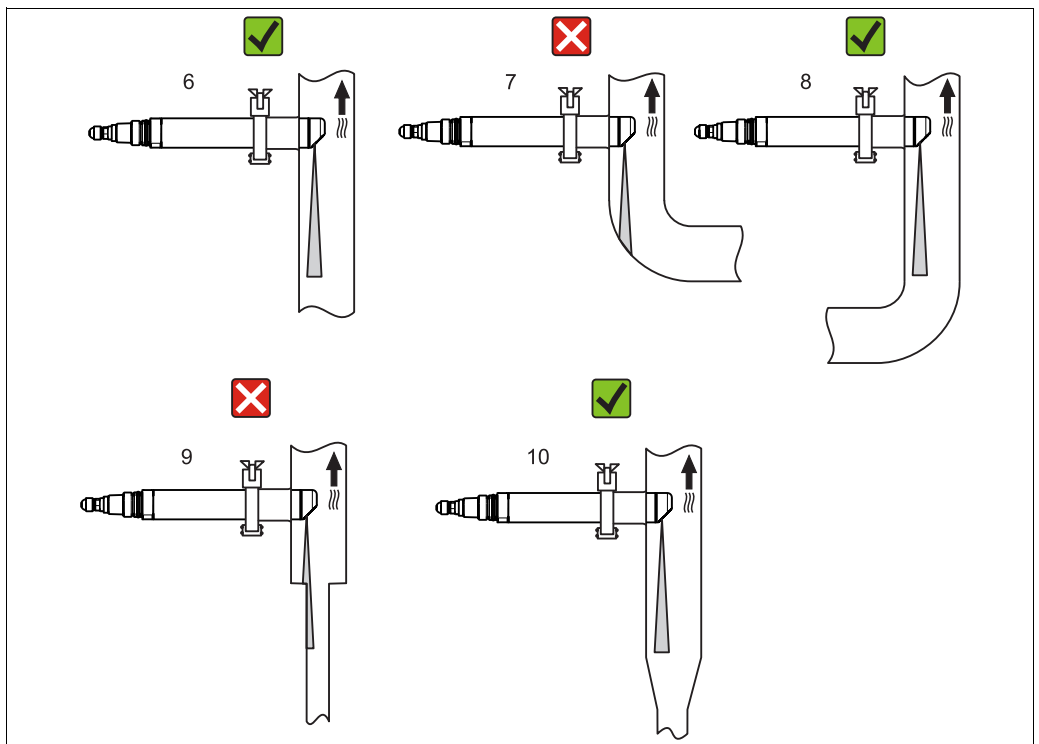

Orientations for pipes and assemblies

- Install the sensor in such a way that the light beam is not reflected (pos. 6).
- Avoid sudden changes in cross-section (pos. 9). Changes in cross-section should be gradual and located as far away as possible from the sensor (pos. 10).
- Do not install the sensor directly downstream from a bend (pos. 7). Instead position it as far away as possible from the bend (pos. 8).
- When using reflective materials (e.g. stainless steel), the pipe diameter must be at least 100 mm (4"). It is recommended that the installation be adjusted on site.
- Pipes made of stainless steel with diameter >DN 300 exhibit hardly any wall effects.

Installation options

Installation options

- with clamp connection
- with Flowfit CUA252 flow assembly
- with Flowfit CUA262 flow assembly
- with Cleanfit CUA451 retractable assembly
- with Flexdip CYA112 immersion assembly and Flexdip CYH112 holder system

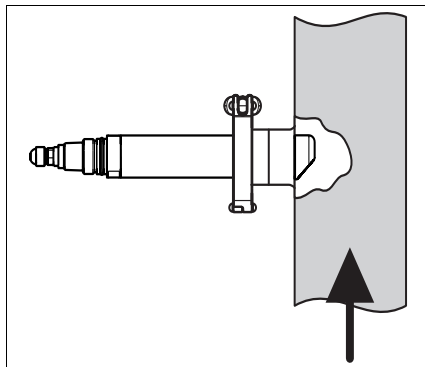

a0022032

Installation with 2° clamp connection

The installation angle is 90°.

The arrow points in the direction of flow.

The optical windows in the sensor must be aligned against the direction of flow.

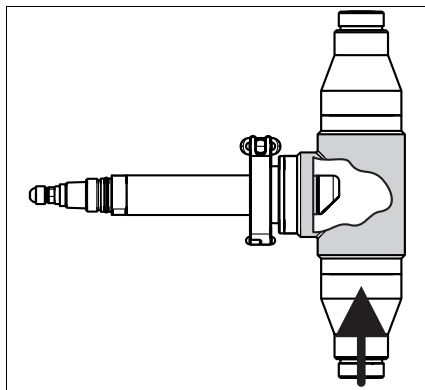

a0022034

Installation with flow assembly CUA252

The installation angle is 90°.

The arrow points in the direction of flow.

The optical windows in the sensor must be aligned against the direction of flow.

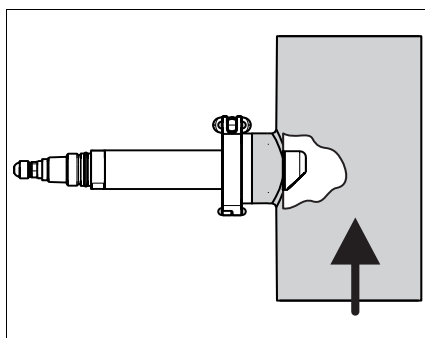

a0022281

Installation with flow assembly CUA262

The installation angle is 90°.

The arrow points in the direction of flow.

The optical windows in the sensor must be aligned against the direction of flow.

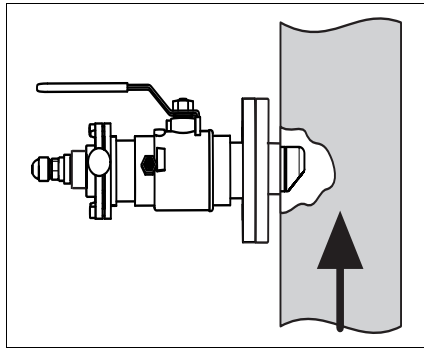

Arrow points in the direction of flow.
 The recommended installation angle is 90°.
 The optical windows in the sensor must be aligned against the direction of flow.
 When using the assembly manually, the medium pressure must not exceed 2 bar (29 psi).

a0022285

Installation with retractable assembly CUA451

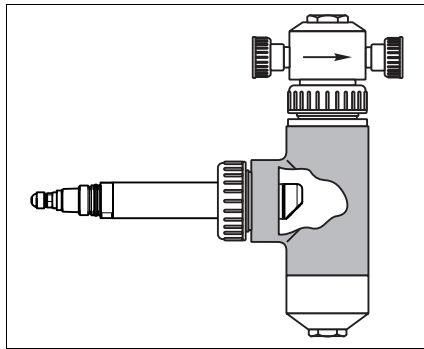

The recommended installation angle is 90°.
 The alignment of the sensor depends on the medium
 For depositing, low outgassing media the optical windows in the sensor must be aligned downwards (see figure on the left).
 For non-depositing, strong outgassing media the optical windows of the sensor must be aligned upwards.

a0022687

Installation with flow assembly CUS31-S

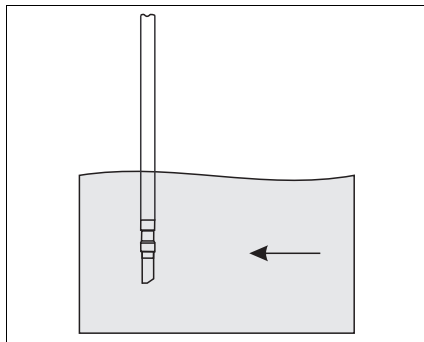

The arrow points in the direction of flow.
 The installation angle is 0°.
 If you are using the sensor in open basins, the sensor must be installed in such a way that bubbles cannot accumulate on it.

a0022033

Installation with immersion assembly

For automatic sensor operation in pipe fittings or flow assemblies, there is the option of using the ultrasonic cleaning system CYR52 (see Accessories).
 Bubbles result in errors in turbidity measurements. This effect of this interference can be minimized by using a bubble trap (see Accessories).

Environment

Ambient temperature	-20 to 85 °C (-4 to 185 °F)
Storage temperature	-20 to 70 °C (-4 to 158 °F)
Degree of protection	IP 68 (test condition: 1.8 m (5.91 ft) water column over 20 days, 1 mol/l KCl)

Process

Process temperature	-20 to 85 °C (-4 to 185 °F)
Process pressure	0.5 to 10 bar (7 to 145 psi) absolute
Minimum flow	No minimum flow required. For solids which have a tendency to form deposits, ensure that sufficient mixing is performed.

Mechanical construction

Design, dimensions

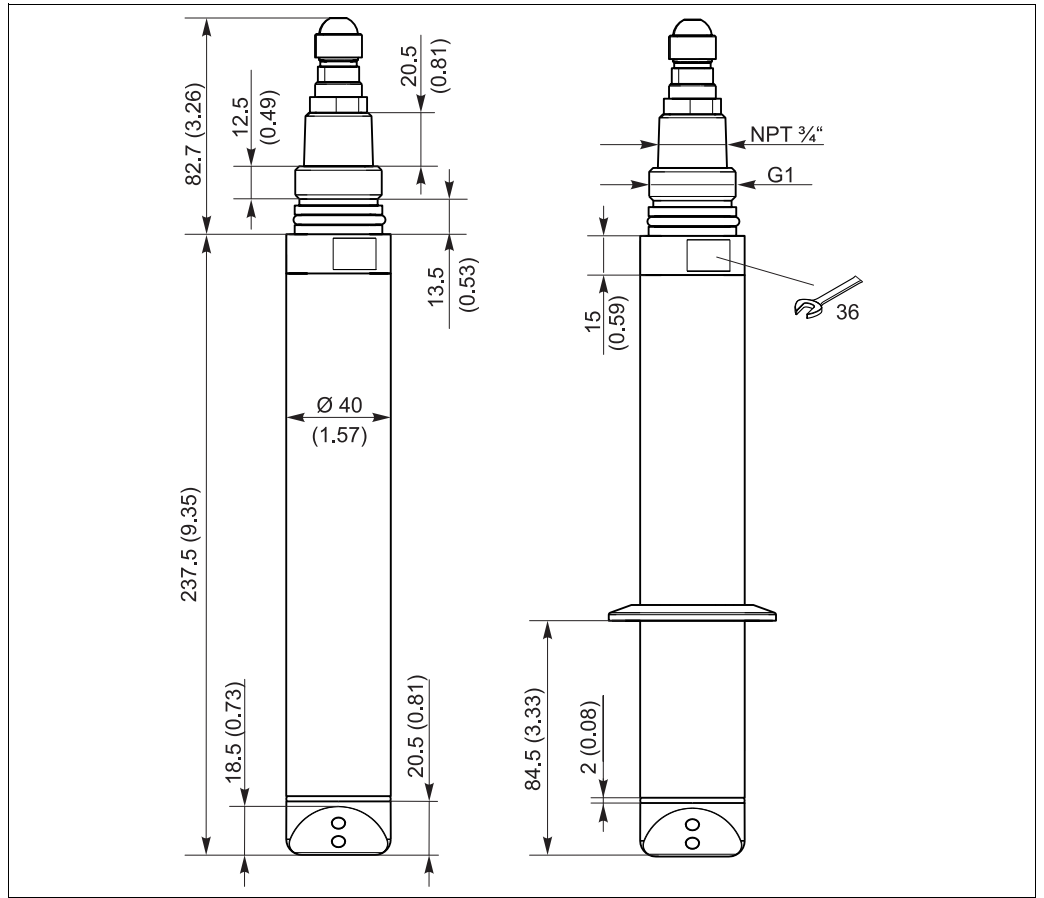

Dimensions in mm (inch)

Compressed air cleaning

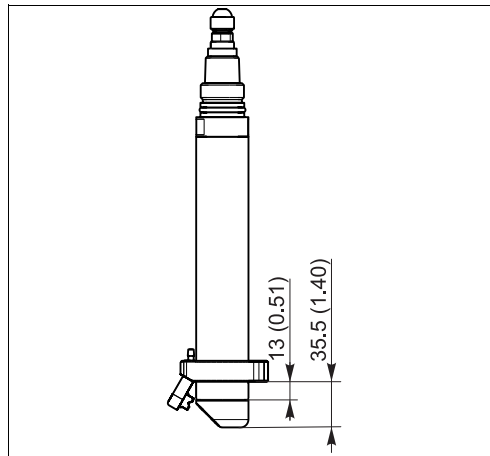

CUS52D with compressed air cleaning

Compressed air cleaning
 Consumption: 50 l/min (13.2 gal/min)
 Back pressure: 1.5 to 2 bar (22 to 30 psi)
 Connection: 6/8 mm or 6.35 mm (1/4")

Solid state reference

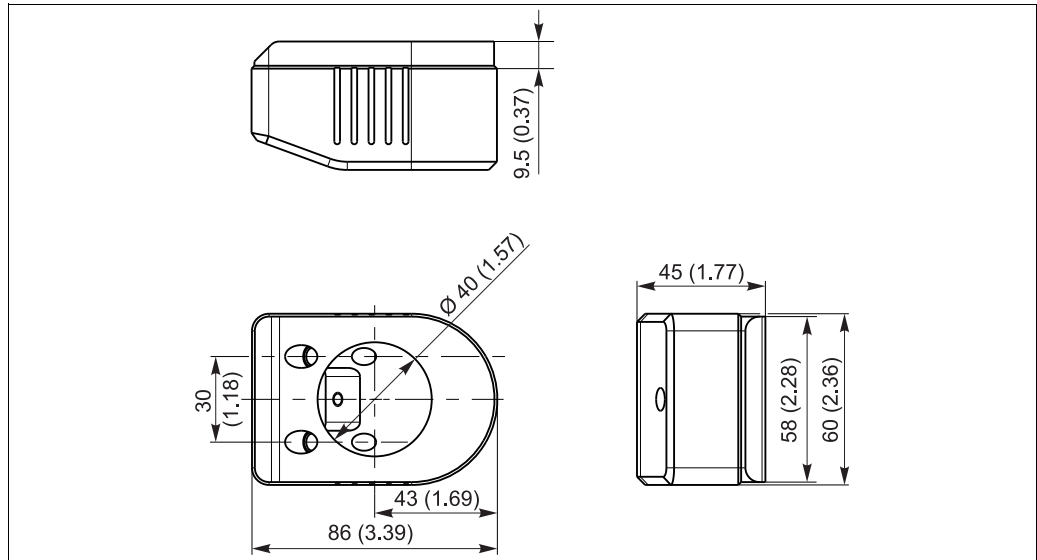

Dimensions in mm (inch)

Weight

Sensor with 7 m cable	
With Tri-Clamp	approx. 1.56 kg
Without Tri-Clamp	approx. 1.48 kg

Materials

Sensor	Stainless steel 1.4404 (AISI 316 L)
Optical windows	Sapphire
O-rings	EPDM

Process connections

G1 and NPT 3/4"
2" clamp (depends on sensor version)/ DIN 32676

Certificates and approvals

Electromagnetic compatibility

Interference emissions and interference immunity in accordance with EN 61326: 2005, Namur NE 21:2007

Ordering information

Order code

You can generate a valid and complete order code on the internet using the Configurator: www.products.endress.com/cus52d

1. On the right-hand side of the product page you will find the following options:

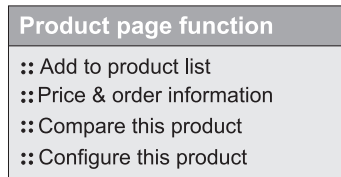

2. Click on "Configure this product".
3. The Configurator opens in a new window. You can now configure your device and will receive a valid and complete order code for it.
4. Now export the order code as a PDF or Excel file. To do this, click on the relevant button at the top of the page.

Scope of supply

The scope of supply comprises:

- 1 Turbimax CUS52D sensor in the version ordered
- 1 Operating Instructions BA01275C/07/EN

Accessories

Assemblies

Flowfit CUA252 flow assembly

- For CUS52D
- Order as per product structure (--> Online Configurator, www.products.endress.com/cua252)
- Technical Information TI01139C/07/EN

Flowfit CUA262 flow assembly

- For CUS52D
- Order as per product structure (--> Online Configurator, www.products.endress.com/cua262)
- Technical Information TI01152C/07/EN

Cleanfit CUA451 retractable assembly

- Manual retractable assembly made of stainless steel with ball valve shut-off for turbidity sensors
- Order as per product structure (--> Online Configurator, www.products.endress.com/cua451)
- Technical Information TI00369C/07/EN

Flexdip CYA112 immersion assembly

- Modular assembly system for sensors in open basins, channels and tanks
- PVC and stainless steel version
- Order as per product structure (--> Online Configurator, www.products.endress.com/cya112)
- Technical Information TI00432C/07/EN

Holder system

Flexdip CYH112 holder system for Flexdip CYA112 water and wastewater assemblies

- Modular holder system for sensors and assemblies in open basins, channels and tanks
- The holder system can be secured in any way, be it on the floor, the cap stone, the wall or directly on a railing.
- Stainless steel version
- Order as per product structure (--> Online Configurator: www.products.endress.com/cyh112)
- Technical Information TI00430C/07/EN

Compressed air cleaning

Compressed air cleaning for CUS52D

- Connection: 6 mm
- Materials: PE black
- Order no.: 71242026

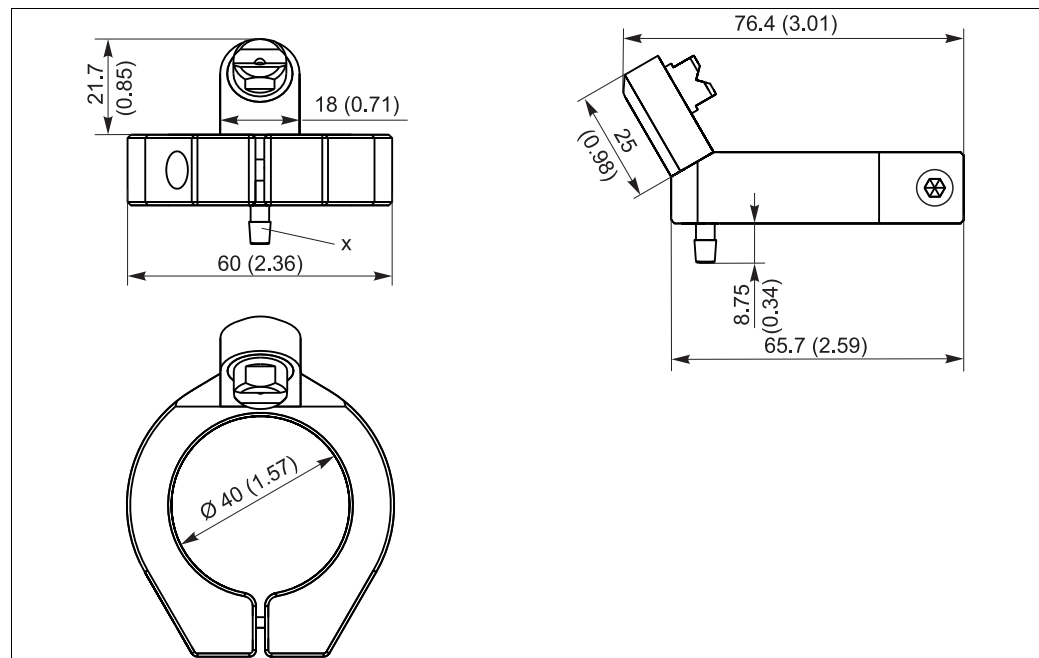

Compressed air cleaning, dimensions in mm (inch)

X 6 mm hose nozzle

Compressor

- For compressed air cleaning
- 230 V AC order no. 71072583
- 115 V AC order no. 71194623

Bubble trap

Bubble trap

- For sensor CUS52D
- Process pressure: up to 3 bar (43.5 psi)
- Process temperature: 0 to 50 °C (32 to 122 °F)
- Adapter to D 12 with connection for vent line (top connection on CUA252), is included in the delivery.
- Orifice plates for the following volume flow rates:
 - < 60 l/h (15.8 gal/hr)
 - 60 to 100 l/h (15.8 to 26.4 gal/hr)
 - > 100 l/h (26.4 gal/hr)
- The vent line is fitted with a PVC hose, hose check valve and a Luer lock adapter.
- Order number, suitable for assembly CUA252: 71242170
- Order number, suitable for assembly S of CUS31: 71247364

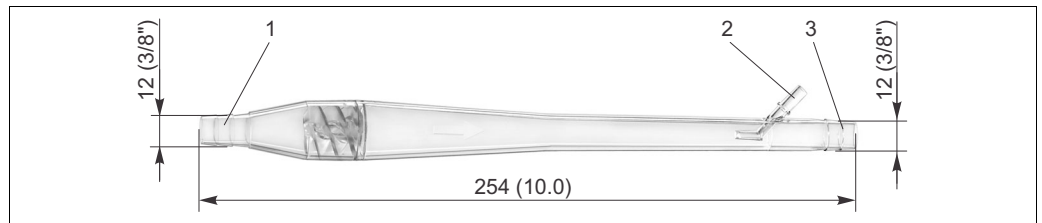

Bubble trap, dimensions in mm (inch)

- 1 Inlet for medium (without hose system)
- 2 Outlet for bubbles (hose system is included in scope of supply)
- 3 Outlet for medium (without hose system)

Calibration set

CUY52 calibration set

- For CUS52D
- Order as per product structure (--> Online Configurator, www.products.endress.com/cuy52)
- Technical Information TI01154C/07/EN

Ultrasonic cleaning

Ultrasonic cleaning system CYR52

- For attachment to assemblies and pipes
- Order as per product structure (--> Online Configurator, www.products.endress.com/cyr52)
- Technical Information TI01153C/07/EN

Transmitter

Liquiline CM44x/CM44xR

- Multi-channel transmitter for connecting digital sensors with Memosens technology
- Field device (CM44x) or DIN rail device (CM44xR)
- Power supply 100 to 230 V AC, 24 V AC/DC
- Universally extensible
- Slot for SD card
- Order as per product structure (--> Configurator on product page)
- Technical Information TI00444C/07/EN (CM44x) or TI01112C/07/EN (CM44xR)

www.addresses.endress.com
