

# Technical Information

## Deltabar S PMD75, FMD77, FMD78

Differential pressure measurement

### Differential pressure transmitter with metal sensors



#### Applications

The device is used for the following measuring tasks:

- Flow measurement (volume flow or mass flow) in conjunction with differential pressure sensors in gases, vapors and liquids
- Level, volume or mass measurements in liquids
- High process temperatures up to 400 °C (752 °F) possible with diaphragm seals mounted

#### The benefits for you

- Very good reproducibility and long-term stability
- High reference accuracy up to 0.035 %
- Turn down up to 100:1, higher on request
- Used for flow and differential pressure monitoring up to SIL3, certified to IEC 61508 by TÜV SÜD
- High level of safety during operation thanks to function monitoring from the measuring cell to the electronics
- The patented TempC diaphragm for the diaphragm seal reduces measured errors caused by environmental and process temperature influences to a minimum
- Easy electronic replacement guaranteed with HistoROM®/M-DAT
- Uniform platform for differential pressure, hydrostatics and pressure (Deltabar S – Deltapilot S – Cerabar S)
- Practical user navigation for quick and easy commissioning
- Extensive diagnostic functions

## Table of contents

<b>Document information</b> . . . . .	<b>4</b>	Total error . . . . .	30
Document function . . . . .	4	Warm-up period . . . . .	30
Symbols used . . . . .	4		
Documentation . . . . .	5	<b>Installation</b> . . . . .	<b>31</b>
Terms and abbreviations . . . . .	5	General installation instructions . . . . .	31
		Measuring arrangement . . . . .	31
<b>Function and system design</b> . . . . .	<b>7</b>	Measuring arrangement for devices with diaphragm seals – FMD77 and FMD78 . . . . .	31
Device features . . . . .	7	Orientation . . . . .	31
Measuring principle . . . . .	8	Wall and pipe mounting . . . . .	32
Product design . . . . .	8	"Separate housing" version . . . . .	33
Communication protocol . . . . .	10	Turning the housing . . . . .	35
		Oxygen applications . . . . .	36
<b>Input</b> . . . . .	<b>11</b>	Ultrapure gas applications . . . . .	36
Measured variable . . . . .	11	Applications with hydrogen . . . . .	36
Measuring range . . . . .	11		
		<b>Environment</b> . . . . .	<b>37</b>
<b>Output</b> . . . . .	<b>12</b>	Ambient temperature range . . . . .	37
Output signal . . . . .	12	Storage temperature range . . . . .	37
Signal range 4 to 20 mA . . . . .	12	Degree of protection . . . . .	37
Signal on alarm . . . . .	12	Climate class . . . . .	37
Maximum load - 4 to 20 mA HART . . . . .	13	Electromagnetic compatibility . . . . .	37
Dead time, time constant . . . . .	13	Vibration resistance . . . . .	38
Dynamic behavior: current output . . . . .	14		
Dynamic behavior: Digital output (HART electronics) . . . . .	14	<b>Process</b> . . . . .	<b>39</b>
Dynamic behavior: PROFIBUS PA . . . . .	15	Process temperature limits (temperature at transmitter) . . . . .	39
Dynamic behavior: FOUNDATION Fieldbus . . . . .	15	Process temperature range, seals . . . . .	40
Damping . . . . .	16	Pressure specifications . . . . .	41
Alarm current . . . . .	16		
Firmware version . . . . .	16	<b>Mechanical construction</b> . . . . .	<b>42</b>
Protocol-specific data . . . . .	16	Device height . . . . .	42
		T14 housing, optional display on the side . . . . .	43
<b>Power supply</b> . . . . .	<b>21</b>	T15 housing, optional display on the top . . . . .	44
Terminal assignment . . . . .	21	T17 housing (hygienic), optional display on the side . . . . .	44
Supply voltage . . . . .	22	Process connections PMD75 . . . . .	45
Current consumption . . . . .	22	Process connections PMD75 . . . . .	46
Electrical connection . . . . .	23	Process connections PMD75 . . . . .	47
Terminals . . . . .	23	FMD77 - Overview . . . . .	48
Cable entries . . . . .	23	Process connections FMD77 with diaphragm seal, high- pressure side . . . . .	49
Connector . . . . .	23	Process connections FMD77 with diaphragm seal, high- pressure side . . . . .	50
Cable specification . . . . .	24	Process connections FMD77 with diaphragm seal, high- pressure side . . . . .	51
Start-up current . . . . .	24	Process connections FMD77 with diaphragm seal, high- pressure side . . . . .	53
Residual ripple . . . . .	24	Process connections FMD77 with diaphragm seal, high- pressure side . . . . .	55
Overtoltage protection (optional) . . . . .	24	Process connections FMD77 with diaphragm seal, low- pressure side . . . . .	55
Influence of power supply . . . . .	25	FMD78 basic device . . . . .	56
		Process connections FMD78 with diaphragm seal . . . . .	57
<b>Performance characteristics of the metallic process isolating diaphragm</b> . . . . .	<b>26</b>	Process connections FMD78 with diaphragm seal . . . . .	58
Reference operating conditions . . . . .	26	Process connections FMD78 with diaphragm seal . . . . .	60
Influence of the installation position . . . . .	26	Process connections FMD78 with diaphragm seal . . . . .	62
Resolution . . . . .	26	Process connections FMD78 with diaphragm seal . . . . .	63
Vibration effects . . . . .	26	Process connections FMD78 with diaphragm seal . . . . .	64
Reference accuracy . . . . .	26	Process connections FMD78 with diaphragm seal . . . . .	65
Thermal change of the zero output and the output span . . . . .	27		
Influence of the operating pressure on the zero point and span . . . . .	29		
Total performance . . . . .	30		
Long-term stability . . . . .	30		





Process connections FMD78 with diaphragm seal . . . . .	66	<b>Registered trademarks . . . . .</b>	<b>99</b>
Separate housing: Wall and pipe mounting with mounting bracket . . . . .	68	HART® . . . . .	99
Materials not in contact with process . . . . .	69	PROFIBUS® . . . . .	99
Materials in contact with process . . . . .	73	FOUNDATION™ Fieldbus . . . . .	99
Fill fluid . . . . .	74	<b>Patents . . . . .</b>	<b>99</b>
<b>Operability . . . . .</b>	<b>75</b>		
Operating concept . . . . .	75		
Local operation . . . . .	75		
Remote operation . . . . .	78		
HistoROM®/M-DAT (optional) . . . . .	79		
System integration . . . . .	80		
<b>Planning instructions, diaphragm seal systems . . .</b>	<b>81</b>		
Applications . . . . .	81		
Design and operation mode . . . . .	82		
Differential pressure transmitter . . . . .	83		
Diaphragm seal filling oils . . . . .	83		
Operating temperature range . . . . .	83		
Response time . . . . .	84		
Information on cleaning . . . . .	85		
Installation instructions . . . . .	85		
Vacuum applications . . . . .	89		
<b>Certificates and approvals . . . . .</b>	<b>90</b>		
CE mark . . . . .	90		
C-tick mark . . . . .	90		
Ex approvals . . . . .	90		
Suitable for hygiene applications . . . . .	90		
Functional safety SIL/ IEC 61508 Declaration of Conformity (optional) . . . . .	90		
Overfill protection . . . . .	90		
CRN approval . . . . .	91		
Other standards and guidelines . . . . .	91		
Pressure Equipment Directive (PED) . . . . .	91		
Marine approval . . . . .	91		
Classification of process sealing between electrical systems and (flammable or combustible) process fluids in accordance with ANSI/ISA 12.27.01 . . . . .	91		
Inspection certificate . . . . .	92		
Calibration . . . . .	92		
<b>Ordering information . . . . .</b>	<b>93</b>		
Scope of delivery . . . . .	93		
Configuration data sheet . . . . .	93		
<b>Accessories . . . . .</b>	<b>96</b>		
HistoROM®/M-DAT . . . . .	96		
Welding flanges and welding neck . . . . .	96		
<b>Supplementary documentation . . . . .</b>	<b>97</b>		
Field of Activities . . . . .	97		
Technical Information . . . . .	97		
Operating Instructions . . . . .	97		
Brief Operating Instructions . . . . .	97		
Functional safety manual (SIL) . . . . .	97		
Overfill protection . . . . .	97		
Safety Instructions (XA) . . . . .	97		
Installation/Control Drawings . . . . .	98		

## Document information







<b>Document function</b>	The document contains all the technical data on the device and provides an overview of the accessories and other products that can be ordered for the device.
--------------------------	---

### Symbols used









#### Safety symbols

Symbol	Meaning
	<b>DANGER!</b> This symbol alerts you to a dangerous situation. Failure to avoid this situation will result in serious or fatal injury.
	<b>WARNING!</b> This symbol alerts you to a dangerous situation. Failure to avoid this situation can result in serious or fatal injury.
	<b>CAUTION!</b> This symbol alerts you to a dangerous situation. Failure to avoid this situation can result in minor or medium injury.
	<b>NOTE!</b> This symbol contains information on procedures and other facts which do not result in personal injury.

#### Electrical symbols

Symbol	Meaning	Symbol	Meaning
	Direct current		Alternating current
	Direct current and alternating current		<b>Ground connection</b> A grounded terminal which, as far as the operator is concerned, is grounded via a grounding system.
	<b>Protective ground connection</b> A terminal which must be connected to ground prior to establishing any other connections.		<b>Equipotential connection</b> A connection that has to be connected to the plant grounding system: This may be a potential equalization line or a star grounding system depending on national or company codes of practice.

#### Symbols for certain types of information

Symbol	Meaning
	<b>Permitted</b> Procedures, processes or actions that are permitted.
	<b>Preferred</b> Procedures, processes or actions that are preferred.
	<b>Forbidden</b> Procedures, processes or actions that are forbidden.
	<b>Tip</b> Indicates additional information.
	Reference to documentation
	Reference to page
	Reference to graphic
	Visual inspection

### Symbols in graphics

Symbol	Meaning
1, 2, 3 ...	Item numbers
1., 2., 3. ...	Series of steps
A, B, C, ...	Views
A-A, B-B, C-C, ...	Sections

### Documentation



The document types listed are available:  
In the Download Area of the Endress+Hauser Internet site: [www.endress.com](http://www.endress.com) → Download

#### Brief Operating Instructions (KA): getting the 1st measured value quickly

The Brief Operating Instructions contain all the essential information from incoming acceptance to initial commissioning.

#### Operating Instructions (BA): your comprehensive reference

These Operating Instructions contain all the information that is required in various phases of the life cycle of the device: from product identification, incoming acceptance and storage, to mounting, connection, operation and commissioning through to troubleshooting, maintenance and disposal.

#### Description of Device Parameters (GP): reference for your parameters

The document provides a detailed explanation of each individual parameter in the operating menu. The description is aimed at those who work with the device over the entire life cycle and perform specific configurations.

#### Safety Instructions (XA)

See the section on Safety Instructions → 97

### Terms and abbreviations

Term/abbreviation	Explanation
BA	Document type "Operating Instructions"
KA	Document type "Brief Operating Instructions"
SD	Document type "Special Documentation"
XA	Document type "Safety Instructions"
PN	Nominal pressure
MWP	The MWP (maximum working pressure) for the individual sensors depends on the lowest-rated element, with regard to pressure, of the selected components, i.e. the process connection must be taken into consideration in addition to the measuring cell. Also observe pressure-temperature dependency. For the relevant standards and additional notes, see the "Pressure specifications" →  41 section. The MWP can also be found on the nameplate.
OPL	The OPL (over pressure limit = sensor overload limit) for the measuring device depends on the lowest-rated element, with regard to pressure, of the selected components, i.e. the process connection has to be taken into consideration in addition to the measuring cell. Also observe pressure-temperature dependency. For the relevant standards and additional notes, see the "Pressure specifications" →  41 section.
LRL	Lower range limit
URL	Upper range limit
LRV	Lower range value
URV	Upper range value
TD	<b>Turn down</b>

Term/abbreviation	Explanation
<p>Case 1 (500 mbar (7.5 psi) measuring cell):                      Lower range value (LRV) <math>\leq</math> Upper range value (URV)                        Example:</p> <ul style="list-style-type: none"> <li>▪ Lower range value (LRV) = 0 mbar</li> <li>▪ Upper range value (URV) = 100 mbar (1.5 psi)</li> <li>▪ Nominal value (URL) = 500 mbar (7.5 psi)</li> </ul> <p>Turn down:                      TD = URL /   URV   = 5:1                      Set span: URV - LRV = 100 mbar (1.5 psi)                      This span is based on the zero point.</p>	<p style="text-align: right;">A0019783</p>
<p>Case 2 (500 mbar (7.5 psi) measuring cell):                      Lower range value (LRV) <math>\geq</math> Upper range value (URV)                        Example:</p> <ul style="list-style-type: none"> <li>▪ Lower range value (LRV) = -300 mbar (-4.5 psi)</li> <li>▪ Upper range value (URV) = 0 mbar</li> <li>▪ Nominal value (URL) = 500 mbar (7.5 psi)</li> </ul> <p>Turn down:                      TD = URL /   LRV   = 1.67:1                      Set span: URV - LRV = 300 mbar (4.5 psi)                      This span is based on the zero point.</p>	<p style="text-align: right;">A0016451</p> <p>1 Set span                      2 Zero-based span                      3 Nominal value <math>\cong</math> Upper range limit (URL)                      4 Nominal measuring range                      5 Sensor measuring range</p>

## Function and system design

### Device features

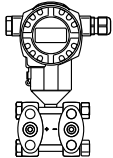
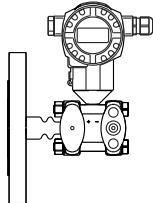
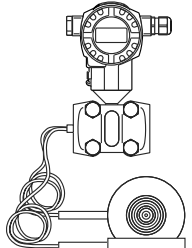
	PMD75	FMD77	FMD78
	 <small>A0023922</small>	 <small>A0023923</small>	 <small>A0023924</small>
		with diaphragm seal installed on one side	with capillary diaphragm seals
Field of application	<ul style="list-style-type: none"> <li>▪ Flow</li> <li>▪ Level</li> <li>▪ Differential pressure</li> </ul>	<ul style="list-style-type: none"> <li>▪ Level</li> <li>▪ Differential pressure</li> </ul>	<ul style="list-style-type: none"> <li>▪ Level</li> <li>▪ Differential pressure</li> </ul>
Process connections	<ul style="list-style-type: none"> <li>▪ 1/4 - 18 NPT</li> <li>▪ RC 1/4</li> </ul>	Low-pressure side (-): <ul style="list-style-type: none"> <li>▪ 1/4 - 18 NPT</li> <li>▪ RC 1/4</li> </ul> High press. side (-): <ul style="list-style-type: none"> <li>▪ DN 50 - DN 100</li> <li>▪ ASME NPS 2" - 4"</li> <li>▪ JIS 80A - 100A</li> </ul>	Wide range of diaphragm seals
Measuring ranges	from -10 to +10 mbar (-0.15 to +0.15 psi) to -40 to +40 bar (-600 to +600 psi)	from -100 to +100 mbar (-1.5 to +1.5 psi) to -16 bar to +16 bar (-240 to +240 psi)	from -100 to +100 mbar (-1.5 to +1.5 psi) to -40 to +40 bar (-600 to +600 psi)
OPL	on one side: to 420 bar (6 300 psi) on both sides: to 630 bar (9 450 psi)	on one side: to 160 bar (2 400 psi) on both sides: to 240 bar (3 600 psi)	on one side: to 160 bar (2 400 psi) on both sides: to 240 bar (3 600 psi)
Process temperature range (temperature at process connection)	-40 to +85 °C (-40 to +185 °F)	-70 to +400 °C (-94 to +752 °F) (depends on filling oil)	-70 to +400 °C (-94 to +752 °F) (depends on filling oil)
Ambient temperature range	<ul style="list-style-type: none"> <li>▪ Without LCD display: -40 to +85 °C (-40 to +185 °F) <sup>1)</sup></li> <li>▪ With LCD display: -20 to +70 °C (-4 to +158 °F)</li> <li>▪ Separate housing: -20 to +60 °C (-4 to +140 °F)</li> <li>▪ Diaphragm seal systems depending on the version</li> </ul>		
Reference accuracy	Up to ±0.035 % of the set span	Up to ±0.075 % of the set span	
Supply voltage non-Ex	<ul style="list-style-type: none"> <li>▪ 4 to 20 mA HART: 10.5 to 45 V DC</li> <li>▪ PROFIBUS PA and FOUNDATION Fieldbus: 9 to 32 V DC</li> </ul>		
Supply voltage Ex ia	10.5 to 30 V DC		
Output	4 to 20 mA with superimposed HART protocol, PROFIBUS PA or FOUNDATION Fieldbus		
Options	High-pressure version to p <sub>stat</sub> 700 bar (10 500 psi)	-	-
	HistoROM®/M-DAT memory chip		
Specialties	<ul style="list-style-type: none"> <li>▪ p<sub>stat</sub> to 420 bar (6 300 psi)</li> <li>▪ Process isolating diaphragm: tantalum</li> <li>▪ Available with Deltatop as flow compact device</li> </ul>	For high media temperatures	Wide range of diaphragm seals

1) lower temperatures on request

## Measuring principle

## Metal process isolating diaphragm

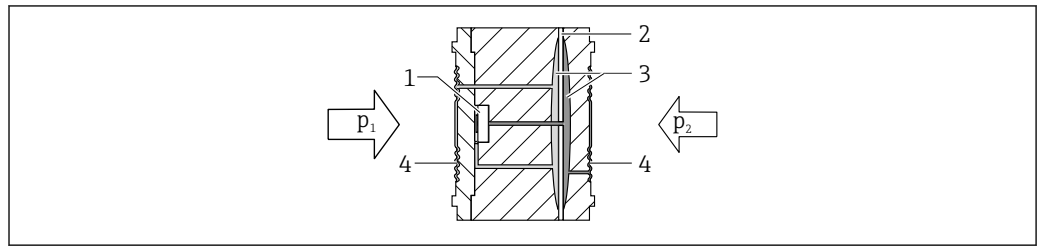

A0023919

- 1 Measuring element
- 2 Middle diaphragm
- 3 Filling oil
- 4 Process isolating diaphragm

The process isolating diaphragms are deflected on both sides by the acting pressures. A filling oil transfers the pressure to a resistance bridge (semiconductor technology). The change in the bridge output voltage, which depends on the differential pressure, is measured and processed

**Advantages:**

- Standard system pressures: 160 bar (2 400 psi) and 420 bar (6 300 psi)
- High long-term stability
- Very high single-sided overload resistance

## Product design

## Flow measurement

Flow measurement with Deltabar S and differential pressure sensor, 1 bar (15 psi)

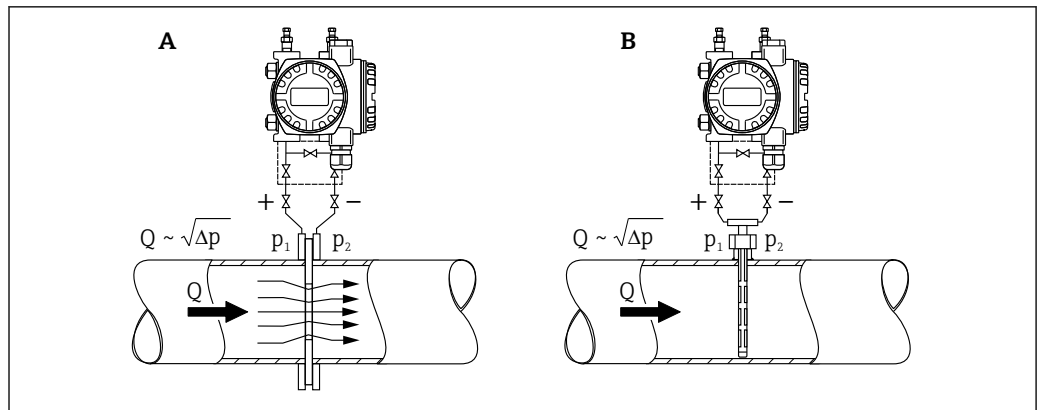

A0023920

- A Orifice plate
- B Pitot tube
- Q Flow
- $\Delta p$  Differential pressure,  $\Delta p = p_1 - p_2$

*The benefits for you*

- Choice of four flow modes of operation: volume flow, corrected volume flow (European norm conditions), standard volume flow (American standard conditions) and mass flow.
- Choice of diverse flow units with automatic unit conversion.
- A customized unit can be specified.
- Low flow cut off: when activated, this function suppresses small flows which can lead to large fluctuations in the measured value.

- Contains two totalizers as standard. One totalizer can be reset to zero.
- The totalizing mode and unit can be individually set for each totalizer. This allows independent daily and annual quantity totalizing.
- With the Deltatop product family, Endress+Hauser is offering universal and reliable solutions for flow measurement: Deltatop is a compact, ready-for-use flow measurement device which includes the Deltabar S differential pressure transmitter

**i** For more information about flow measurement with the Deltabar S differential pressure transmitter

- Deltabar S with orifice plate (TI00422P, Deltatop DO6x)
- Deltabar S with Pitot tube (TI00425P, Deltatop DP6x)

**Level measurement (level, volume and mass):**

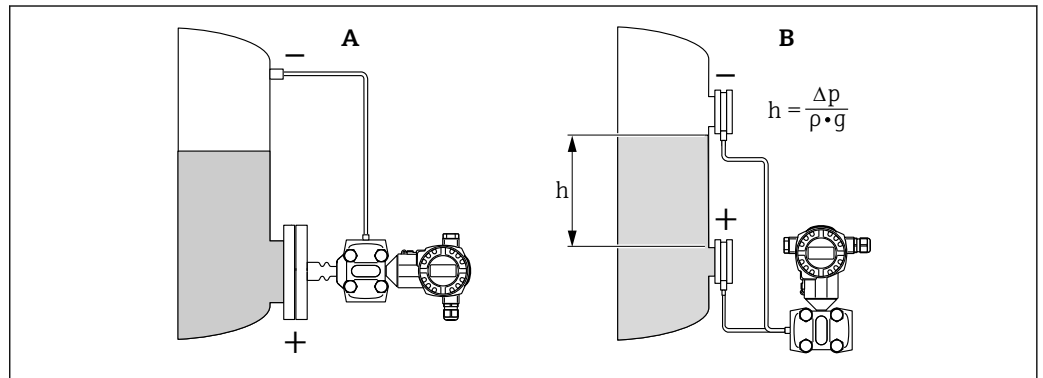

A0023921

A Level measurement with FMD77

B Level measurement with FMD78

h Height (level)

$\Delta p$  Differential pressure

$\rho$  Density of the medium

g Gravitational constant

*The benefits for you*

- Selection of the level operating mode which is optimum for your application in the device software.
- Volume and mass measurements in any container shapes by means of a freely programmable characteristic curve.
- Choice of diverse level units with automatic unit conversion.
- A customized unit can be specified.
- Has a wide range of uses, e.g.
  - for level measurement in vessels with pressure overlay
  - in the event of foam formation
  - in containers with agitators or screen fittings
  - in the event of liquid gases
  - for standard level measurement

---

**Communication protocol**

- 4 to 20 mA with HART communication protocol
- PROFIBUS PA
  - The Endress+Hauser devices meet the requirements of the FISCO model.
  - Due to a low current consumption of  $13 \text{ mA} \pm 1 \text{ mA}$ , the following number of devices can be operated on one bus segment if installing as per FISCO: up to 7 devices for Ex ia, CSA IS and FM IS applications or up to 27 devices for all other applications e.g. in non-hazardous areas, Ex nA etc.  
Further information on PROFIBUS PA can be found in Operating Instructions BA00034S "PROFIBUS DP/PA: Guidelines for planning and commissioning" and in the PNO Guideline.
- FOUNDATION Fieldbus
  - The Endress+Hauser devices meet the requirements of the FISCO model.
  - Due to a low current consumption of  $15.5 \text{ mA} \pm 1 \text{ mA}$ , the following number of devices can be operated on one bus segment if installing as per FISCO: up to 6 devices for Ex ia, CSA IS and FM IS applications or up to 24 devices for all other applications e.g. in non-hazardous areas, Ex nA etc.  
Further information on FOUNDATION Fieldbus, such as requirements for bus system components, can be found in Operating Instructions BA00013S "FOUNDATION Fieldbus Overview".

## Input

<b>Measured variable</b>	<b>Measured process variables</b>
	Differential pressure
	<b>Calculated process variables</b>
	<ul style="list-style-type: none"> <li>■ Flow rate (volume flow or mass flow)</li> <li>■ Level (level, volume or mass)</li> </ul>

### Measuring range

Nominal value	Range limit		Lowest calibratable span <sup>1)</sup>	MWP	OPL		Min. operating pressure <sup>2)</sup>	Option <sup>3)</sup>
	lower (LRL)	upper (URL)			on one side	on both sides		
[mbar (psi)]	[mbar (psi)]	[mbar (psi)]	[mbar (psi)]	[bar (psi)]	[bar (psi)]	[bar (psi)]	[mbar <sub>abs</sub> (psi <sub>abs</sub> )]	
<b>FMD77, FMD78, PMD75: Option PN 160/16 MPa/2400 psi</b>								
10 (0.15) (PMD75 only)	-10 (-0.15)	+10 (+0.15)	0.25 (0.00375)	160 (2400)	160 (2400)	240 (3600)	0.1 (0.0015)	7B
30 (0.45) (PMD75 only)	-30 (-0.45)	+30 (+0.45)	0.3 (0.0045)	160 (2400) <sup>6)</sup>	160 (2400)	240 (3600)		7C
100 (1.5)	-100 (-1.5)	+100 (+1.5)	1/5 (0.015/0.075) <sup>5)</sup>					7D
500 (7.5)	-500 (-7.5)	+500 (+7.5)	5 (0.075)					7F
3000 (45)	-3000 (-45)	+3000 (+45)	30 (0.45)					7H
16000 (240)	-16000 (-240)	+16000 (+240)	160 (2.4)					7L
40000 (600)	-40000 (-600)	+40000 (+600)	400 (6)					"+" side <sup>7)</sup> : 160 (2400)
<b>PMD75: Option PN 420/42 MPa/6300 psi</b>								
100 (1.5)	-100 (-1.5)	+100 (+1.5)	1/5 (0.015/0.075) <sup>5)</sup>	420 (6300) <sup>6)</sup>	420 (6300)	630 (9450)	0.1 (0.0015)	8D
500 (7.5)	-500 (-7.5)	+500 (+7.5)	5 (0.075)	420 (6300)	420 (6300)	630 (9450)		8F
3000 (45)	-3000 (-45)	+3000 (+45)	30 (0.45)					8H
16000 (240)	-16000 (-240)	+16000 (+240)	160 (2.4)					8L
40000 (600)	-40000 (-600)	+40000 (+600)	400 (6)					"+" side <sup>7)</sup> : 420 (6300)

- 1) Turn down > 100:1 on request
- 2) The minimum operating pressure indicated in the table applies to silicone oil under reference operating conditions. Min. system pressure at 85 °C (185 °F) for silicone oil: up to 10 mbar<sub>abs</sub> (0.15 psi<sub>abs</sub>). FMD77 and FMD78: Min. system pressure: 50 mbar<sub>abs</sub> (0.75 psi<sub>abs</sub>); the pressure and temperature application limits of the selected filling oil must be observed. Please observe the installation instructions for vacuum applications → 89.
- 3) Product Configurator, order code for "Nominal range; PN"
- 4) Screws → 72
- 5) Smallest calibratable span for the PMD75: 1 mbar (0.015 psi); Smallest calibratable span for the FMD77 and FMD78: 5 mbar (0.075 psi)
- 6) For PMD75 devices with a CRN-approved process connection, the MWP is: if O-rings are used: 315 bar (4 725 psi); if PTFE and CU seals are used: 120 bar (1 800 psi)
- 7) "-" side: 100 bar (1 500 psi)

## Output

### Output signal

- 4 to 20 mA with superimposed digital communication protocol HART, 2-wire
- Digital communication signal PROFIBUS PA (Profile 3.0), 2-wire
  - Signal coding: Manchester Bus Powered (MBP): Manchester II
  - Transmission rate: 31.25 KBit/s voltage mode
- Digital communication signal FOUNDATION Fieldbus, 2-wire
  - Signal coding: Manchester Bus Powered (MBP): Manchester II
  - Transmission rate: 31.25 KBit/s voltage mode

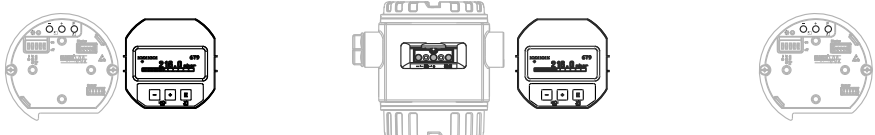
Output	Internal + LCD	External + LCD	Internal
			
	Option <sup>1)</sup>		
4 to 20mA HART	B	A	C
4 to 20mA HART, Li=0	E	D	F
PROFIBUS PA	N	M	O
FOUNDATION Fieldbus	Q	P	R

1) Product Configurator order code for "Display, operation: "

**Signal range 4 to 20 mA** 3.8 mA to 20.5 mA

**Signal on alarm** As per NAMUR NE43

#### 4 to 20 mA HART

- Max. alarm: Can be set between 21 to 23 mA (factory setting: 22 mA)
- Hold measured value: last measured value is held
- Min. alarm: 3.6 mA

#### PROFIBUS PA

Can be set in the Analog Input Block.

Options:

- Last Valid Out Value (factory setting)
- Fail Safe Value
- Status bad

#### FOUNDATION Fieldbus

Can be set in the Analog Input Block.

Options:

- Last Good Value
- Fail Safe Value (factory setting)
- Wrong Value

**Maximum load - 4 to 20 mA HART**

In order to guarantee sufficient terminal voltage in two-wire devices, a maximum load resistance R (including line resistance) must not be exceeded depending on the supply voltage  $U_0$  of the supply unit. In the following load diagrams, observe the position of the jumper and the explosion protection:

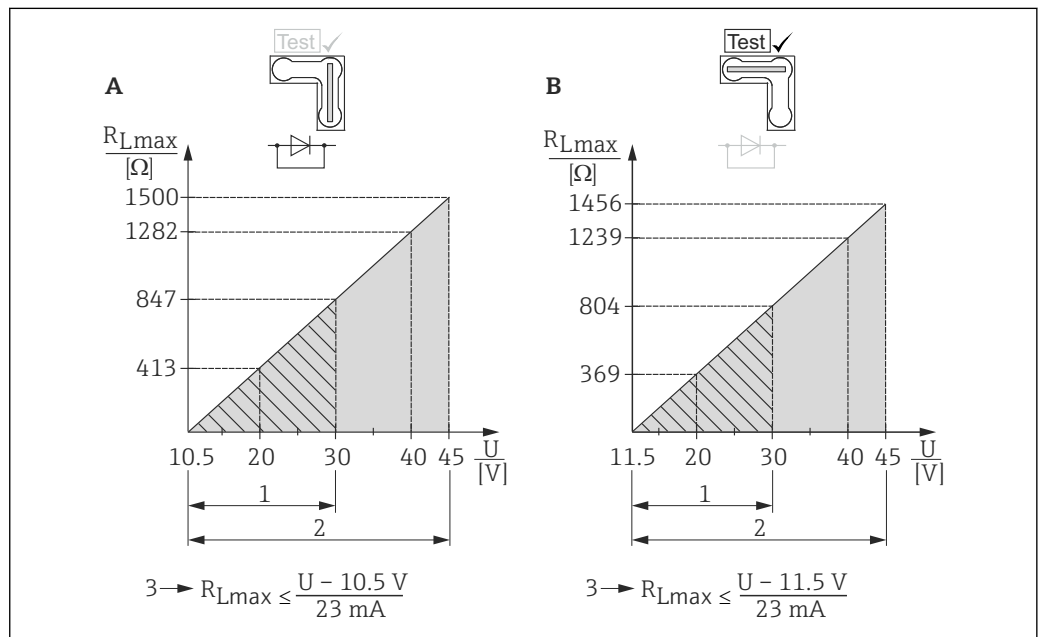

A0019988

- A Jumper for 4 to 20 mA test signal set to "Non-test" position
- B Jumper for 4 to 20 mA test signal set to "Test" position
- 1 Power supply 10.5 (11.5) to 30 V DC for 1/2 G Ex ia, 1GD Ex ia, 1/2 GD Ex ia, FM IS, CSA IS, IECEx ia, NEPSI Ex ia
- 2 Power supply 10.5 (11.5) to 45 V DC for devices for non-hazardous areas, 1/2 D, 1/3 D, 2 G Ex d, 3 G Ex nA, FM XP, FM DIP, FM NI, CSA XP, CSA dust ignition-proof, NEPSI Ex d
- 3  $R_{Lmax}$  maximum load resistance
- U Supply voltage

 When operating via a handheld terminal or via a PC with an operating program, a minimum communication resistance of 250  $\Omega$  must be taken into account.

**Dead time, time constant**

Presentation of the dead time and the time constant:

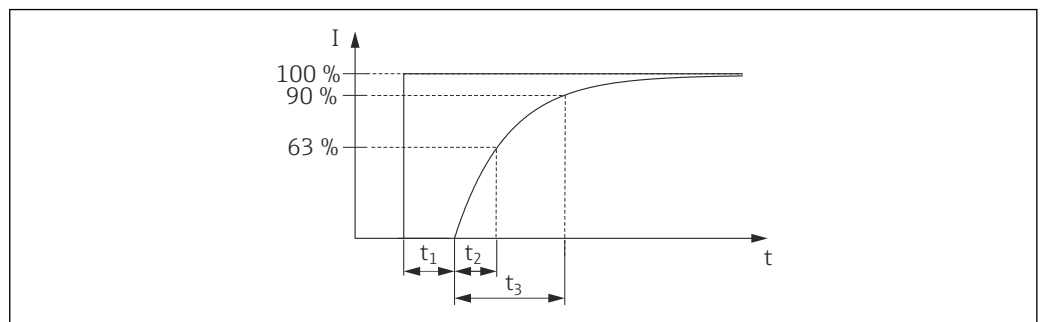

A0019786

**Dynamic behavior:  
current output**

Type		Measuring cell	Dead time (t <sub>1</sub> ) [ms]	Time constant T63 (t <sub>2</sub> ) [ms]	Time constant T90 (t <sub>3</sub> ) [ms]
PMD75	Max.	<ul style="list-style-type: none"> <li>▪ 10 mbar (0.15 psi) and 30 mbar (0.45 psi)</li> <li>▪ 100 mbar (1.5 psi)</li> <li>▪ 500 mbar (7.5 psi)</li> <li>▪ 3 bar (45 psi)</li> <li>▪ 16 bar (240 psi)</li> </ul>	45	<ul style="list-style-type: none"> <li>▪ 450</li> <li>▪ 60</li> <li>▪ 45</li> <li>▪ 40</li> <li>▪ 60</li> </ul>	<ul style="list-style-type: none"> <li>▪ 1040</li> <li>▪ 138</li> <li>▪ 104</li> <li>▪ 92</li> <li>▪ 138</li> </ul>
FMD77, FMD78	Max.	Dependent on the diaphragm seal			

**Dynamic behavior: Digital  
output (HART electronics)**

A typical burst rate of 300 ms results in the following behavior:

Type		Measuring cell	Dead time (t <sub>1</sub> ) [ms]	Dead time (t <sub>1</sub> ) [ms] + Time constant T63 (t <sub>2</sub> ) [ms]	Dead time (t <sub>1</sub> ) [ms] + Time constant T90 (t <sub>3</sub> ) [ms]
PMD75	Min.	<ul style="list-style-type: none"> <li>▪ 10 mbar (0.15 psi) and 30 mbar (0.45 psi)</li> <li>▪ 100 mbar (1.5 psi)</li> <li>▪ 500 mbar (7.5 psi)</li> <li>▪ 3 bar (45 psi)</li> <li>▪ 16 bar (240 psi)</li> </ul>	205	<ul style="list-style-type: none"> <li>▪ 655</li> <li>▪ 265</li> <li>▪ 250</li> <li>▪ 245</li> <li>▪ 265</li> </ul>	<ul style="list-style-type: none"> <li>▪ 1200</li> <li>▪ 298</li> <li>▪ 264</li> <li>▪ 252</li> <li>▪ 298</li> </ul>
	Max.	<ul style="list-style-type: none"> <li>▪ 10 mbar (0.15 psi) and 30 mbar (0.45 psi)</li> <li>▪ 100 mbar (1.5 psi)</li> <li>▪ 500 mbar (7.5 psi)</li> <li>▪ 3 bar (45 psi)</li> <li>▪ 16 bar (240 psi)</li> </ul>	1005	<ul style="list-style-type: none"> <li>▪ 1455</li> <li>▪ 1065</li> <li>▪ 1050</li> <li>▪ 1045</li> <li>▪ 1065</li> </ul>	<ul style="list-style-type: none"> <li>▪ 2000</li> <li>▪ 1098</li> <li>▪ 1064</li> <li>▪ 1052</li> <li>▪ 1098</li> </ul>
FMD77, FMD78	Max.	Dependent on the diaphragm seal			

**Reading cycle**

- Acyclic: max. 3/s, typically 1/s (depending on command # and number of preambles)
- Cyclic (burst): max. 3/s, typically 2/s

The device commands the BURST MODE functionality for cyclical value transmission via the HART communication protocol.

**Cycle time (update time)**

Cyclic (burst): min. 300 ms

**Response time**

- Acyclic: min. 330 ms, typically 590 ms (depending on command # and number of preambles)
- Cyclic (burst): min. 160 ms, typically 350 ms (depending on command # and number of preambles)

**Dynamic behavior:** PROFIBUS PA A typical PLC cycle time of 1 s results in the following behavior:

Type		Measuring cell	Dead time (t <sub>1</sub> ) [ms]	Dead time (t <sub>1</sub> ) [ms] + Time constant T63 (t <sub>2</sub> ) [ms]	Dead time (t <sub>1</sub> ) [ms] + Time constant T90 (t <sub>3</sub> ) [ms]
PMD75	Min.	<ul style="list-style-type: none"> <li>■ 10 mbar (0.15 psi) and 30 mbar (0.45 psi)</li> <li>■ 100 mbar (1.5 psi)</li> <li>■ 500 mbar (7.5 psi)</li> <li>■ 3 bar (45 psi)</li> <li>■ 16 bar (240 psi)</li> </ul>	80	<ul style="list-style-type: none"> <li>■ 530</li> <li>■ 140</li> <li>■ 125</li> <li>■ 120</li> <li>■ 140</li> </ul>	<ul style="list-style-type: none"> <li>■ 1075</li> <li>■ 173</li> <li>■ 139</li> <li>■ 127</li> <li>■ 173</li> </ul>
	Max.	<ul style="list-style-type: none"> <li>■ 10 mbar (0.15 psi) and 30 mbar (0.45 psi)</li> <li>■ 100 mbar (1.5 psi)</li> <li>■ 500 mbar (7.5 psi)</li> <li>■ 3 bar (45 psi)</li> <li>■ 16 bar (240 psi)</li> </ul>	1280	<ul style="list-style-type: none"> <li>■ 1730</li> <li>■ 1340</li> <li>■ 1325</li> <li>■ 1320</li> <li>■ 1340</li> </ul>	<ul style="list-style-type: none"> <li>■ 2275</li> <li>■ 1373</li> <li>■ 1339</li> <li>■ 1327</li> <li>■ 1373</li> </ul>
FMD77, FMD78	Max.	Dependent on the diaphragm seal			

**Reading cycle (PLC)**

- Acyclic: Typically 25/s
- Cyclic: Typically 30/s (depending on the number and type of the function blocks used in the closed-control loop)

**Cycle time (update time)**

Min. 200 ms

The cycle time in a bus segment in cyclic data communication depends on the number of devices, on the segment coupler used and on the internal PLC cycle time. A new measured value can be determined up to five times a second.

**Response time**

- Acyclic: Approx. 60 ms to 70 ms (depending on Min. Slave Interval)
- Cyclic: Approx. 10 ms to 13 ms (depending on Min. Slave Interval)

**Dynamic behavior:** FOUNDATION Fieldbus A typical configuration for the macro cycle time (host system) of 1 s results in the following behavior:

Type		Measuring cell	Dead time (t <sub>1</sub> ) [ms]	Dead time (t <sub>1</sub> ) [ms] + Time constant T63 (t <sub>2</sub> ) [ms]	Dead time (t <sub>1</sub> ) [ms] + Time constant T90 (t <sub>3</sub> ) [ms]
PMD75	Min.	<ul style="list-style-type: none"> <li>■ 10 mbar (0.15 psi) and 30 mbar (0.45 psi)</li> <li>■ 100 mbar (1.5 psi)</li> <li>■ 500 mbar (7.5 psi)</li> <li>■ 3 bar (45 psi)</li> <li>■ 16 bar (240 psi)</li> </ul>	90	<ul style="list-style-type: none"> <li>■ 540</li> <li>■ 150</li> <li>■ 135</li> <li>■ 130</li> <li>■ 150</li> </ul>	<ul style="list-style-type: none"> <li>■ 1085</li> <li>■ 183</li> <li>■ 149</li> <li>■ 137</li> <li>■ 183</li> </ul>
	Max.	<ul style="list-style-type: none"> <li>■ 10 mbar (0.15 psi) and 30 mbar (0.45 psi)</li> <li>■ 100 mbar (1.5 psi)</li> <li>■ 500 mbar (7.5 psi)</li> <li>■ 3 bar (45 psi)</li> <li>■ 16 bar (240 psi)</li> </ul>	1090	<ul style="list-style-type: none"> <li>■ 1540</li> <li>■ 1150</li> <li>■ 1135</li> <li>■ 1130</li> <li>■ 1150</li> </ul>	<ul style="list-style-type: none"> <li>■ 2085</li> <li>■ 1183</li> <li>■ 1149</li> <li>■ 1137</li> <li>■ 1183</li> </ul>
FMD77, FMD78	Max.	Dependent on the diaphragm seal			

**Reading cycle**

- Acyclic: Typically 10/s
- Cyclic: Max. 10/s (depending on the number and type of the function blocks used in the closed-control loop)

**Cycle time (update time)**

Cyclic: Min. 100 ms

**Response time**

- Acyclic: Typically 100 ms (for standard bus parameter settings)
- Cyclic: Max. 20 ms (for standard bus parameter settings)

**Damping**

A damping affects all outputs (output signal, display):

- Via onsite display, handheld terminal or PC with operating program, continuous from 0 to 999 s
- Also for HART and PROFIBUS PA: Via DIP switch on the electronic insert, switch position "on" = set value and "off"
- Factory setting: 2 s

**Alarm current**

Description	Option <sup>1)</sup>
Min alarm current	J
HART burst mode PV	
Min alarm current + HART burst mode PV	

1) Product Configurator, order code for "Additional options 1" and "Additional options 2"

**Firmware version**

Description	Option <sup>1)</sup>
02.20.zz, HART, DevRev22	72
02.11.zz, HART, DevRev21	73
04.00.zz, FF, DevRev07	74
04.01.zz, PROFIBUS PA, DevRev03	75
02.10.zz, HART, DevRev21	76
03.00.zz, FF, DevRev06	77
04.00.zz, PROFIBUS PA	78

1) Product Configurator order code for "Firmware version"

**Protocol-specific data****HART**

Manufacturer ID	17 (11 hex)
Device type code	23 (17 hex)
Device revision	<ul style="list-style-type: none"> <li>▪ 21 (15 hex) - SW version 02.1y.zz - HART specification 5</li> <li>▪ 22 (16 hex) - SW version 02.2y.zz - HART specification 7</li> </ul>
HART specification	<ul style="list-style-type: none"> <li>▪ 5</li> <li>▪ 7</li> </ul>
DD revision	<ul style="list-style-type: none"> <li>▪ 4 (Russian in language selection) for device revision 21</li> <li>▪ 3 (Dutch in language selection) for device revision 21</li> <li>▪ 1 for device revision 22</li> </ul>
Device description files (DTM, DD)	Information and files at: <ul style="list-style-type: none"> <li>▪ <a href="http://www.endress.com">www.endress.com</a></li> <li>▪ <a href="http://www.hartcomm.org">www.hartcomm.org</a></li> </ul>
HART load	Min. 250 Ω

HART device variables	<p>The measured values are assigned to the device variables as follows:</p> <p><b>Measured values for PV (primary variable)</b></p> <ul style="list-style-type: none"> <li>▪ Pressure</li> <li>▪ Flow</li> <li>▪ Level</li> <li>▪ Tank content</li> </ul> <p><b>Measured values for SV, TV (second and third variable)</b></p> <ul style="list-style-type: none"> <li>▪ Pressure</li> <li>▪ Totalizer</li> </ul> <p><b>Measured values for QV (fourth variable)</b></p> <p>Temperature</p>
Supported functions	<ul style="list-style-type: none"> <li>▪ Burst mode</li> <li>▪ Additional transmitter status</li> <li>▪ Device locking</li> <li>▪ Alternative operating modes</li> </ul>

**PROFIBUS PA**

Manufacturer ID	17 (11 hex)
Identification number	1542 hex
Profile version	<p>3.0</p> <ul style="list-style-type: none"> <li>▪ SW version 03.00.zz</li> <li>▪ SW version 04.00.zz</li> </ul> <p>3.02</p> <p>SW version 04.01.zz ( device revision 3)</p> <p>Compatibility with SW version 03.00.zz and higher.</p>
GSD revision	<ul style="list-style-type: none"> <li>▪ 4 (SW version 3.00.zz and 4.00.zz)</li> <li>▪ 5 (device revision 3)</li> </ul>
DD revision	<ul style="list-style-type: none"> <li>▪ 1 (SW version 3.00.zz and 4.00.zz)</li> <li>▪ 1 (device revision 3)</li> </ul>
GSD file	Information and files at:
DD files	<ul style="list-style-type: none"> <li>▪ <a href="http://www.endress.com">www.endress.com</a></li> <li>▪ <a href="http://www.profibus.org">www.profibus.org</a></li> </ul>
Output values	<p><b>Measured value for PV (via Analog Input Function Block)</b></p> <ul style="list-style-type: none"> <li>▪ Pressure</li> <li>▪ Level</li> <li>▪ Flow</li> <li>▪ Tank content</li> </ul> <p><b>Measured value for SV</b></p> <ul style="list-style-type: none"> <li>▪ Pressure</li> <li>▪ Temperature</li> </ul> <p><b>Measured value for QV</b></p> <p>Totalizer</p>
Input values	Input value sent from PLC, can be shown on display
Supported functions	<ul style="list-style-type: none"> <li>▪ Identification &amp; maintenance Simplest device identifier on the control system and nameplate</li> <li>▪ Condensed status (only with Profile Version 3.02)</li> <li>▪ Automatic ID number adjustment and switchable to the following ID numbers (only with Profile Version 3.02): <ul style="list-style-type: none"> <li>- 9700: Profile-specific transmitter identification number with the "Classic" or "Condensed" status".</li> <li>- 1504: Compatibility mode for the old Deltabar S generation (FMD230, FMD630, FMD633, PMD230, PMD235).</li> <li>- 1542: Identification number for the new Deltabar S device generation ( FMD77, FMD78, PMD75).</li> </ul> </li> <li>▪ Device locking: The device can be locked by hardware or software.</li> </ul>

**FOUNDATION Fieldbus**

Manufacturer ID	452B48 hex
Device type	1009 hex
Device revision	<ul style="list-style-type: none"> <li>▪ 6 - SW version 03.00.zz</li> <li>▪ 7 - SW version 04.00.zz (FF-912)</li> </ul>
DD revision	<ul style="list-style-type: none"> <li>▪ 3 (device revision 6)</li> <li>▪ 2 (device revision 7)</li> </ul>
CFF revision	<ul style="list-style-type: none"> <li>▪ 4 (device revision 6)</li> <li>▪ 1 (device revision 7)</li> </ul>
DD files	Information and files at:
CFF files	<ul style="list-style-type: none"> <li>▪ <a href="http://www.endress.com">www.endress.com</a></li> <li>▪ <a href="http://www.fieldbus.org">www.fieldbus.org</a></li> </ul>
Device tester version (ITK version)	<ul style="list-style-type: none"> <li>▪ 5.0 (device revision 6)</li> <li>▪ 6.01 (device revision 7)</li> </ul>
Number of ITK test campaign	<ul style="list-style-type: none"> <li>▪ IT054700 (Device Revision 6)</li> <li>▪ IT085400 (Device Revision 7)</li> </ul>
Link Master (LAS) capable	Yes
Choice of "Link Master" and "Basic Device"	Yes, factory setting is Basic Device
Node address	Factory setting: 247 (F7 hex)
Supported functions	<p>Field diagnostics profile (only with FF912)</p> <p>The following methods are supported:</p> <ul style="list-style-type: none"> <li>▪ Restart</li> <li>▪ Configure error as warning or alarm</li> <li>▪ HistoROM</li> <li>▪ Peakhold</li> <li>▪ Alarm info</li> <li>▪ Sensor trim</li> </ul>
Number of VCRs	<ul style="list-style-type: none"> <li>▪ 44 (device revision 6)</li> <li>▪ 24 (device revision 7)</li> </ul>
Number of link objects in VFD	50

*Virtual communication references (VCRs)*

	Device revision 6	Device revision 7
Permanent entries	44	1
Client VCRs	0	0
Server VCRs	5	10
Source VCRs	8	43
Sink VCRs	0	0
Subscriber VCRs	12	43
Publisher VCRs	19	43

*Link settings*

	Device revision 6	Device revision 7
Slot time	4	4
Min. Inter PDU delay	12	10
Max. response delay	10	10

*Transducer Blocks*

Block	Content	Output values
TRD1 Block	Contains all parameters related to the measurement	<ul style="list-style-type: none"> <li>■ Pressure, flow or level (channel 1)</li> <li>■ Process temperature (channel 2)</li> </ul>
Service Block	Contains service information	<ul style="list-style-type: none"> <li>■ Pressure after damping (channel 3)</li> <li>■ Pressure peakhold indicator (channel 4)</li> <li>■ Totalizer for max. pressure exceeded (channel 5)</li> </ul>
Dp Flow Block	Contains flow and totalizer parameter	Totalizer 1 (channel 6)
Diagnostic Block	Contains diagnostic information	Error code via DI channels (channel 0 to 16)
Display Block	Contains parameters to configure the onsite display	No output values

*Function blocks*

Block	Content	Number blocks	Execution time		Functionality	
			Device Revision 6	Device Revision 7	Device Revision 6	Device Revision 7
Resource Block	This block contains all the data that uniquely identifies the device; it is an electronic version of a nameplate for the device.	1			enhanced	enhanced
Analog Input Block 1 Analog Input Block 2 Analog Input Block 3	The AI Block receives the measuring data from the Sensor Block, (selectable via a channel number) and makes the data available to other function blocks at its output. Enhancement: Digital outputs for process alarms, fail safe mode	3	45 ms	45 ms (without trend and alarm reports)	enhanced	enhanced
Digital Input Block	This block contains the discrete data of the Diagnose Block (selectable via a channel number 0 to 16) and provides them for other blocks at the output.	1	40 ms	30 ms	standard	enhanced
Digital Output Block	This block converts the discrete input and thus initiates an action (selectable via a channel number) in the DP Flow Block or in the Service Block. Channel 1 resets the max. overpressure meter.	1	60 ms	40 ms	standard	enhanced
PID Block	This block is used as a proportional-integral-derivative controller and can be used universally for closed-loop-control in the field. It enables cascade mode and feedforward control. Input IN can be indicated on the display. The selection is performed in the Display Block (DISPLAY_MAIN_LINE_CONTENT).	1	120 ms	70 ms	standard	enhanced
Arithmetic Block	This block is designed to permit simple use of popular measurement math functions. The user does not have to know how to write equations. The math algorithm is selected by name, chosen by the user for the function to be performed.	1	50 ms	40 ms	standard	enhanced
Input Selector Block	The Input Selector Block facilitates the selection of up to four inputs and generates an output based on the configured action. This block normally receives its inputs from AI Blocks. The block performs maximum, minimum, average and 'first good' signal selection. Inputs IN1 to IN4 can be indicated on the display. The selection is performed in the Display Block (DISPLAY_MAIN_LINE_CONTENT).	1	35 ms	35 ms	standard	enhanced
Signal Characterizer Block	The Signal Characterizer Block has two sections, each with an output that is a non-linear function of the respective input. The non-linear function is generated by a single look-up table with 21 arbitrary x-y pairs.	1	30 ms	40 ms	standard	enhanced

Block	Content	Number blocks	Execution time		Functionality	
			Device Revision 6	Device Revision 7	Device Revision 6	Device Revision 7
Integrator Block	The Integrator Block integrates a variable as a function of the time or accumulates the counts from a Pulse Input Block. The block can be used as a totalizer that counts up until a reset, or as a batch totalizer whereby the integrated value is compared against a target value generated before or during the control routine and generates a binary signal when the target value is reached.	1	35 ms	40 ms	standard	enhanced
Analog Alarm Block	This block contains all process alarm conditions (working like a comparator) and represents them at the output.	1	35 ms	35 ms	standard	enhanced

*Additional function block information:*

Instantiatable function blocks	YES	YES
Number of additional instantiatable function blocks	9	4

## Power supply

### **⚠ WARNING**

**Electrical safety is compromised by an incorrect connection.**

- ▶ When using the measuring device in hazardous areas, installation must comply with the corresponding national standards and regulations and the Safety Instructions or Installation or Control Drawings → 97.
- ▶ All explosion protection data are given in separate documentation which is available upon request. The Ex documentation is supplied as standard with all devices approved for use in explosion hazardous areas → 97.
- ▶ Devices with integrated overvoltage protection must be grounded → 24.
- ▶ Protective circuits against reverse polarity, HF influences and overvoltage peaks are integrated.

### Terminal assignment

#### 4 to 20 mA HART

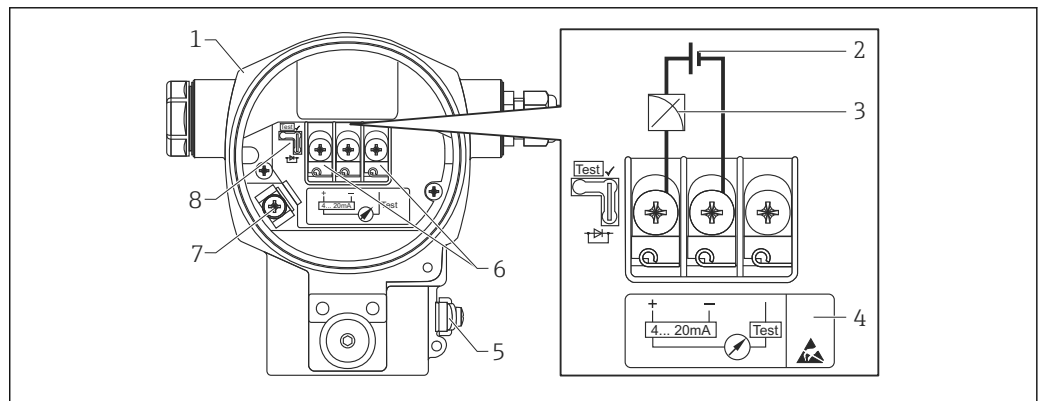

- 1 Housing
- 2 Supply voltage
- 3 4 to 20 mA
- 4 Devices with integrated overvoltage protection are labeled "OVP" (overvoltage protection) here.
- 5 External ground terminal
- 6 4 to 20 mA test signal between positive and test terminal
- 7 Internal ground terminal
- 8 Jumper for 4 to 20 mA test signal

#### PROFIBUS PA and FOUNDATION Fieldbus

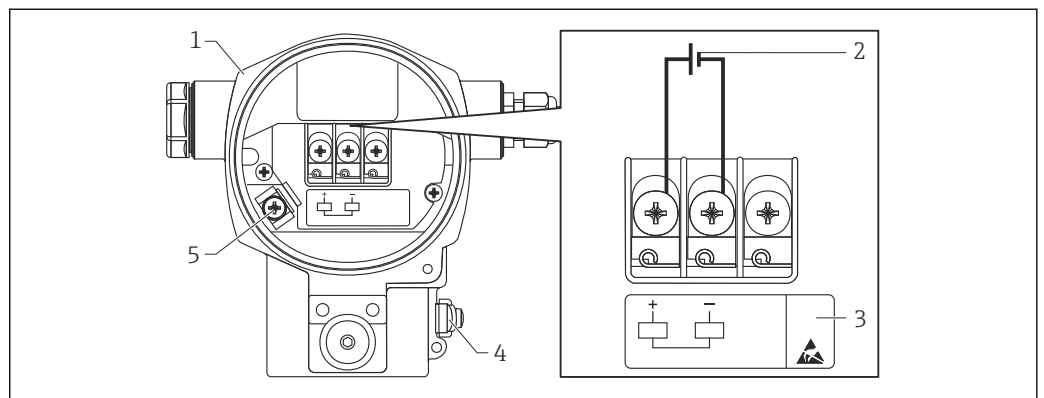

- 1 Housing
- 2 Supply voltage
- 3 Devices with integrated overvoltage protection are labeled "OVP" (overvoltage protection) here.
- 4 External ground terminal
- 5 Internal ground terminal



## Supply voltage

## 4 to 20 mA HART

Electronic version	Jumper for 4 to 20 mA test signal in "Test" position (delivery status)	Jumper for 4 to 20 mA test signal in "Non-test" position
Version for non-hazardous area	11.5 to 45 V DC	10.5 to 45 V DC
Intrinsically safe	11.5 to 30 V DC	10.5 to 30 V DC
<ul style="list-style-type: none"> <li>▪ Other types of protection</li> <li>▪ Devices without certificate</li> </ul>	11.5 to 45 V DC (versions with 35 V DC plug-in connection)	10.5 to 45 V DC (versions with 35 V DC plug-in connection)

*Measuring a 4 to 20 mA test signal*

A 4 to 20 mA test signal may be measured via the positive and test terminal without interrupting the measurement. The minimum supply voltage of the device can be reduced by simply changing the position of the jumper. As a result, operation is also possible with lower voltage sources. Observe the position of the jumper in accordance with the following table.

Jumper position for test signal	Description
 A0019992	<ul style="list-style-type: none"> <li>▪ Measurement of 4 to 20 mA test signal via the positive and test terminal: Possible. (Thus, the output current can be measured without interruption via the diode.)</li> <li>▪ Delivery status</li> <li>▪ Minimum supply voltage: 11.5 V DC</li> </ul>
 A0019993	<ul style="list-style-type: none"> <li>▪ Measurement of 4 to 20 mA test signal via positive and test terminal: Not possible.</li> <li>▪ Minimum supply voltage: 10.5 V DC</li> </ul>

**PROFIBUS PA**

- Version for non-hazardous areas: 9 to 32 V DC
- Ex ia: 10.5 to 30 V DC

**FOUNDATION Fieldbus**

- Version for non-hazardous areas: 9 to 32 V DC
- Ex ia: 10.5 to 30 V DC

## Current consumption

- PROFIBUS PA: 13 mA ± 1 mA, switch-on current corresponds to IEC 61158-2, Clause 21
- FOUNDATION Fieldbus: 15.5 mA ± 1 mA, switch-on current corresponds to IEC 61158-2, Clause 21

**Electrical connection**

**PROFIBUS PA**

The digital communication signal is transmitted to the bus via a 2-wire connection. The bus also provides the power supply. For further information on the network structure and grounding, and for further bus system components such as bus cables, see the relevant documentation, e.g. Operating Instructions BA00034S "PROFIBUS DP/PA: Guidelines for planning and commissioning" and the PNO Guideline.

**FOUNDATION Fieldbus**

The digital communication signal is transmitted to the bus via a 2-wire connection. The bus also provides the power supply. For further information on the network structure and grounding and for further bus system components such as bus cables, see the relevant documentation, e.g. Operating Instructions BA00013S "FOUNDATION Fieldbus Overview" and the FOUNDATION Fieldbus Guideline.

**Terminals**

- Supply voltage and internal ground terminal: 0.5 to 2.5 mm<sup>2</sup> (20 to 14 AWG)
- External ground terminal: 0.5 to 4 mm<sup>2</sup> (20 to 12 AWG)

**Cable entries**

Approval	Cable gland	Clamping area
Standard, II 1/2 G Ex ia, IS	Plastic M20x1.5	5 to 10 mm (0.2 to 0.39 in)
ATEX II 1/2 D, II 1/3 D, II 1/2 GD Ex ia, II 1 GD Ex ia, II 3 G Ex nA	Metal M20x1.5 (Ex e)	7 to 10.5 mm (0.28 to 0.41 in)

For additional technical data, see section on housing → 43

**Connector**

**Devices with Harting plug Han7D**

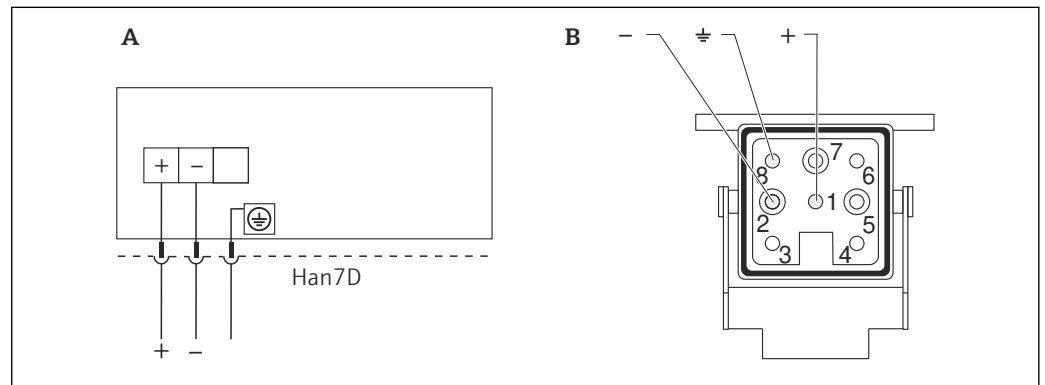

A Electrical connection for devices with Harting plug Han7D  
 B View of the plug-in connection on the device

Material: CuZn, gold-plated plug-in jack and plug

**Devices with M12 plug**

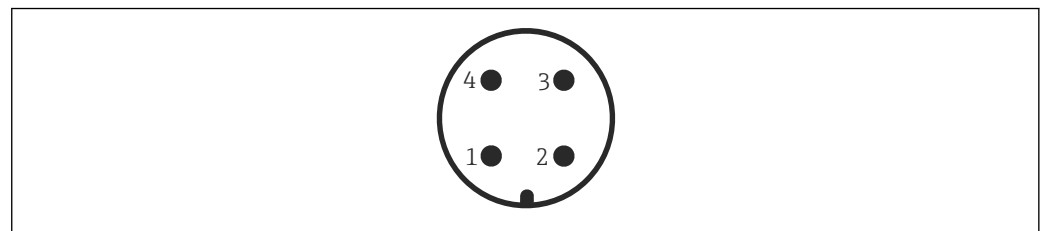

- 1 Signal +
- 2 Not assigned
- 3 Signal -
- 4 Ground

Endress+Hauser offers the following accessories for devices with an M12 plug:

Plug-in jack M 12x1, straight

- Material: Body PA; coupling nut CuZn, nickel-plated
- Degree of protection (fully locked): IP67
- Order number: 52006263

Plug-in jack M 12x1, elbowed

- Material: Body PBT/PA; coupling nut GD-Zn, nickel-plated
- Degree of protection (fully locked): IP67
- Order number: 71114212

Cable 4 x 0.34 mm<sup>2</sup> (20 AWG) with M12 socket, elbowed, screw plug, length 5 m (16 ft)

- Material: Body PUR; coupling nut CuSn/Ni; cable PVC
- Degree of protection (fully locked): IP67
- Order number: 52010285

#### Devices with 7/8" plug

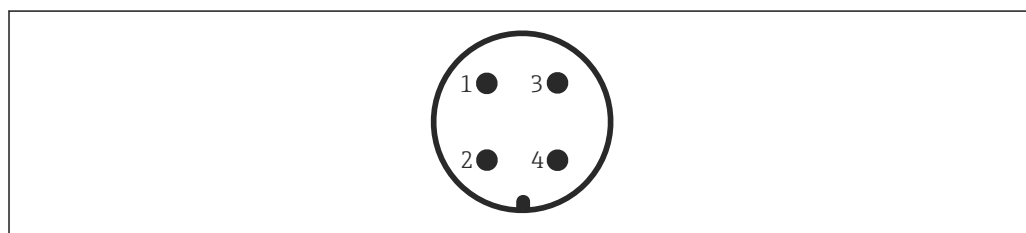

A001176

- 1 Signal -
- 2 Signal +
- 3 Not assigned
- 4 Shielding

External thread: 7/8 - 16 UNC

- Material: 316L (1.4401)
- Degree of protection: IP68

#### Cable specification

##### HART

- Endress+Hauser recommends using shielded, twisted-pair two-wire cables.
- Cable outer diameter: 5 to 9 mm (0.2 to 0.35 in) depending on the cable entry used → 23

##### PROFIBUS PA

Use a twisted, shielded twin-core cable, preferably cable type A.

- For further information regarding cable specifications, see the Operating Instructions BA00034S "PROFIBUS DP/PA: Guidelines for planning and commissioning", the PNO guideline 2.092 "PROFIBUS PA User and Installation Guideline" and IEC 61158-2 (MBP).

##### FOUNDATION Fieldbus

Use a twisted, shielded twin-core cable, preferably cable type A.

- For further information on the cable specifications, see Operating Instructions BA00013S "FOUNDATION Fieldbus Overview", FOUNDATION Fieldbus Guideline and IEC 61158-2 (MBP).

#### Start-up current

12 mA

#### Residual ripple

Without influence on 4 to 20 mA signal up to ±5% residual ripple within the permitted voltage range [according to HART hardware specification HCF\_SPEC-54 (DIN IEC 60381-1)].

#### Overvoltage protection (optional)

- Overvoltage protection:
  - Nominal functioning DC voltage: 600 V
  - Nominal discharge current: 10 kA
- Surge current check  $\hat{i} = 20$  kA satisfied as per DIN EN 60079-14: 8/20  $\mu$ s
- Arrester AC current check  $I = 10$  A satisfied

Ordering information: Product Configurator, order code for "Additional options 1" or Additional options 2", version "M"

**NOTICE**

**Device could be destroyed!**

- ▶ Devices with integrated overvoltage protection must be grounded.

---

**Influence of power supply**       $\leq 0.0006 \% \text{ URL}/1 \text{ V}$

## Performance characteristics of the metallic process isolating diaphragm

### Reference operating conditions

- As per IEC 60770
- Ambient temperature  $T_A$  = constant, in range: +21 to +33 °C (+70 to +91 °F)
- Humidity  $\varphi$  = constant, in the range of: 5 to 80 % rH
- Ambient pressure  $p_A$  = constant, in range: 860 to 1060 mbar (12.47 to 15.37 psi)
- Position of the measuring cell = constant, in range: horizontal  $\pm 1^\circ$  (see also "Influence of the installation position" section →  26)
- Input of LOW SENSOR TRIM and HIGH SENSOR TRIM for lower range value and upper range value
- Zero based span
- Material of the process isolating diaphragm for PMD75: AISI 316L (1.4435), alloy C276, gold-rhodium coated, Monel
- Material of the process isolating diaphragm for FMD77, FMD78: AISI 316L (1.4435)
- Filling oil: silicone oil
- Material of the PMD75 side flange: AISI 316L (1.4435)
- Supply voltage: 24 V DC  $\pm 3$  V DC
- Load with HART: 250  $\Omega$

### Influence of the installation position

- PMD75:  $\leq 4$  mbar (0.06 psi). Device is rotated vertically to the axis of the process isolating diaphragm.
- FMD77:  $\leq 32$  mbar (0.48 psi). Device rotated vertically to the process isolating diaphragm of the flange.

The value is doubled for devices with inert oil.

 Position-dependent zero shift can be corrected →  31 and →  85.

### Resolution

- Current output: 1  $\mu$ A
- Display: can be set (factory setting: presentation of the maximum accuracy of the transmitter)

### Vibration effects

Device/accessory	Measuring cells	Housing	Test standard	Vibration resistance
PMD75	10 mbar (0.15 psi), 30 mbar (0.45 psi)	T14 stainless steel T15 aluminum T17 aluminum	IEC 61298-3	$\leq 0.15\%$ URL to 10 to 38 Hz: $\pm 0.35$ mm (0.0138 in); 38 to 2000 Hz: 2 g in all 3 planes
		T14 aluminum	IEC 61298-3	$\leq 0.15\%$ URL to 10 to 60 Hz: $\pm 0.21$ mm (0.0083 in); 60 to 2000 Hz: 3 g in all 3 planes
	$\geq 100$ mbar (1.5 psi)	T14 stainless steel T15 aluminum	IEC 61298-3	$\leq$ reference accuracy to 10 to 38 Hz: $\pm 0.35$ mm (0.0138 in); 38 to 2000 Hz: 2 g in all 3 planes
		T14 aluminum	IEC 61298-3	$\leq$ reference accuracy to 10 to 60 Hz: $\pm 0.35$ mm (0.0138 in); 60 to 2000 Hz: 5 g in all 3 planes

### Reference accuracy

The reference accuracy contains the non-linearity [DIN EN 61298-2 3.11] including the pressure hysteresis [DIN EN 61298-23.13] and non-repeatability [DIN EN 61298-2 3.11] in accordance with the limit point method as per [DIN EN 60770]. The specifications refer to the calibrated span.

The following applies to the quadratic characteristic curve: The accuracy data of the Deltabar S is considered in the accuracy calculation of the flow rate with a factor of 0.5.

**PMD75**

Measuring cell	% of the set span	
10 mbar (0.15 psi), 30 mbar (0.45 psi)	<ul style="list-style-type: none"> <li>■ TD 1:1 = ±0.09</li> <li>■ TD &gt; 1:1 = ±0.09 x TD</li> </ul>	
100 mbar (1.5 psi)	<ul style="list-style-type: none"> <li>■ TD 1:1 to TD 4:1 = ±0.075</li> <li>■ TD &gt; 4:1 = ±(0.012 x TD + 0.027)</li> </ul>	
500 mbar (7.5 psi)	<ul style="list-style-type: none"> <li>■ TD 1:1 to TD 15:1 = ±0.075</li> <li>■ TD &gt; 15:1 = ±(0.0015 x TD + 0.053)</li> </ul>	
3 bar (45 psi), 16 bar (240 psi), 40 bar (600 psi)	<ul style="list-style-type: none"> <li>■ TD 1:1 to TD 15:1 = ±0.05</li> <li>■ TD &gt; 15:1 = ±(0.0015 x TD + 0.0275)</li> </ul>	
Platinum version: 100 mbar (1.5 psi), 500 mbar (7.5 psi)	TD 1:1	= ±0.05
Platinum version: 3 bar (45 psi), 16 bar (240 psi), 40 bar (600 psi)	TD 1:1	= ±0.035

**FMD77, FMD78**

Measuring cell	FMD77	FMD78
	% of the set span (additionally influence of the diaphragm seal)	
100 mbar (1.5 psi)	<ul style="list-style-type: none"> <li>■ TD 1:1 to TD 4:1 = ±0.15</li> <li>■ TD &gt; 4:1 = ±(0.03 x TD + 0.03)</li> </ul>	<ul style="list-style-type: none"> <li>■ TD 1:1 to TD 4:1 = ±0.15</li> <li>■ TD &gt; 4:1 = ±(0.03 x TD + 0.03)</li> </ul>
500 mbar (7.5 psi), 3 bar (45 psi), 16 bar (240 psi)	<ul style="list-style-type: none"> <li>■ TD 1:1 to TD 15:1 = ±0.075</li> <li>■ TD &gt; 15:1 = ±(0.0015 x TD + 0.053)</li> </ul>	<ul style="list-style-type: none"> <li>■ TD 1:1 to TD 4:1 = ±0.15</li> <li>■ TD &gt; 4:1 = ±(0.02 x TD + 0.07)</li> </ul>
40 bar (600 psi)	—	<ul style="list-style-type: none"> <li>■ TD 1:1 to TD 4:1 = ±0.15</li> <li>■ TD &gt; 4:1 = ±(0.02 x TD + 0.07)</li> </ul>

**Thermal change of the zero output and the output span PMD75**

Measuring cell	-10 to +60 °C (+14 to +140 °F)			
	AISI 316L/1.4435 or alloy C276 Process isolating diaphragm	Gold-rhodium Process isolating diaphragm	Monel Process isolating diaphragm	Tantalum Process isolating diaphragm
	% of the set span			
10 mbar (0.15 psi), 30 mbar (0.45 psi)	±(0.30 x TD + 0.06)	±(0.60 x TD + 0.1)	±(0.60 x TD + 0.2)	±(0.5 x TD + 0.15)
100 mbar (1.5 psi)	±(0.18 x TD + 0.02)	±(0.18 x TD + 0.02)	±(0.18 x TD + 0.02)	±(0.23 x TD + 0.07)
500 mbar (7.5 psi), 3 bar (45 psi)	±(0.08 x TD + 0.05)			
16 bar (240 psi)	±(0.1 x TD + 0.10)			
40 bar (600 psi)	±(0.08 x TD + 0.05)			

Measuring cell	-40 to -10 °C (-40 to +14 °F) +60 to +85 °C (+140 to +185 °F)
	all process isolating diaphragm materials
	% of the set span
10 mbar (0.15 psi), 30 mbar (0.45 psi)	$\pm(0.45 \times \text{TD} + 0.10)$
100 mbar (1.5 psi)	$\pm(0.30 \times \text{TD} + 0.15)$
500 mbar (7.5 psi), 3 bar (45 psi)	$\pm(0.12 \times \text{TD} + 0.10)$
16 bar (240 psi),	$\pm(0.15 \times \text{TD} + 0.20)$
40 bar (600 psi)	$\pm(0.37 \times \text{TD} + 0.10)$

**Influence of the operating pressure on the zero point and span**



The influence of the operating pressure on the zero point can be corrected.

Material of the Process isolating diaphragm	AISI 316L (1.4435), alloy C276		Gold-rhodium <sup>1)</sup>	
Measuring cell	Influence of the operating pressure		Influence of the operating pressure	
	on the zero point	on the span	on the zero point	on the span
10 mbar (0.15 psi)	±0.15% of URL/ 7 bar (105 psi)	±0.035% of URL/ 7 bar (105 psi)	±0.15% of URL/ 7 bar (105 psi)	±0.035% of URL/ 7 bar (105 psi)
30 mbar (0.45 psi)	±0.50% of URL/ 70 bar (1050 psi)	±0.14% of URL/ 70 bar (1050 psi)	±0.77% of URL/ 70 bar (1050 psi)	±0.14% of URL/ 70 bar (1050 psi)
100 mbar (1.5 psi)	±0.15% of URL/ 70 bar (1050 psi)	±0.14% of URL/ 70 bar (1050 psi)	±0.42% of URL/ 70 bar (1050 psi)	±0.42% of URL/ 70 bar (1050 psi)
500 mbar (7.5 psi)	±0.075% of URL/ 70 bar (1050 psi)	±0.14% of URL/ 70 bar (1050 psi)	±0.075% of URL/ 70 bar (1050 psi)	±0.14% of URL/ 70 bar (1050 psi)
3 bar (45 psi)				
16 bar (240 psi)				
40 bar (600 psi)				

1) The material of the process isolating diaphragm is Alloy C276 for PMD75 and 316L for FMD77/FMD78. The coating of the process isolating diaphragm is gold-rhodium.

Material of the Process isolating diaphragm	Monel		Tantalum	
Measuring cell	Influence of the operating pressure		Influence of the operating pressure	
	on the zero point	on the span	on the zero point	on the span
10 mbar (0.15 psi)	±0.21% of URL/ 7 bar (105 psi)	±0.05% of URL/ 7 bar (105 psi)	±0.32% of URL/ 7 bar (105 psi)	±0.07% of URL/ 7 bar (105 psi)
30 mbar (0.45 psi)	±1.05% of URL/ 70 bar (1050 psi)	±0.21% of URL/ 70 bar (1050 psi)	±1.60% of URL/ 70 bar (1050 psi)	±0.32% of URL/ 70 bar (1050 psi)
100 mbar (1.5 psi)	±0.42% of URL/ 70 bar (1050 psi)	±0.42% of URL/ 70 bar (1050 psi)	±0.42% of URL/ 70 bar (1050 psi)	±0.42% of URL/ 70 bar (1050 psi)
500 mbar (7.5 psi)	±0.075% of URL/ 70 bar (1050 psi)	±0.14% of URL/ 70 bar (1050 psi)	±0.14% of URL/ 70 bar (1050 psi)	±0.14% of URL/ 70 bar (1050 psi)
3 bar (45 psi)				
16 bar (240 psi)				
40 bar (600 psi)				

**Total performance**

The "Total performance" specification comprises the non-linearity including hysteresis, non-repeatability, the thermal change of the zero point and static pressure influence  $p_{st} = 70 \text{ bar (1 050 psi)}$ .

All specifications apply to the temperature range  $-10 \text{ to } +60 \text{ }^\circ\text{C (+14 to } +140 \text{ }^\circ\text{F)}$ .

**PMD75**

Measuring cell	AISI 316L/1.4435 or alloy C276 P Process isolating diaphragm	Gold-rhodium Process isolating diaphragm	Monel Process isolating diaphragm	Tantalum process isolating diaphragm
	% of set span <sup>1)</sup>			
10 mbar (0.15 psi)	±0.35	±0.64	±0.66	±0.61
30 mbar (0.45 psi)	±0.77	±0.99	±1.22	±1.66
100 mbar (1.5 psi)	±0.27	±0.50	±0.50	±0.30
to TD 2:1: 500 mbar (7.5 psi), 3 bar (45 psi), 16 bar (240 psi), 40 bar (600 psi)	±0.15	±0.15	±0.15	±0.30

1) For measuring cells  $\leq 30 \text{ mbar (0.45 psi)}$  TD 1:1, for measuring cells  $\geq 100 \text{ mbar (1.5 psi)}$  TD 2:1

**Long-term stability**

Measuring ranges	1 year	5 years	10 years
	% of URL		
10 mbar (0.15 psi), 30 mbar (0.45 psi)	±0.200	±0.280	±0.310
100 mbar (1.5 psi)	±0.180	–	–
500 mbar (7.5 psi)	±0.025	±0.050	±0.075
3 bar (45 psi)	±0.038	±0.075	±0.150
16 bar (240 psi)	±0.025	±0.110	±0.210

**Total error**

The total error comprises the total performance and long-term stability.

Measuring cell	AISI 316L/1.4435 or alloy C276 P Process isolating diaphragm	Gold-rhodium Process isolating diaphragm	Monel Process isolating diaphragm	Tantalum process isolating diaphragm
	% of URL/year			
10 mbar (0.15 psi)	±0.40	±0.67	±0.69	±0.64
30 mbar (0.45 psi)	±0.79	±1.01	±1.24	±1.67
100 mbar (1.5 psi)	±0.33	±0.50	±0.50	±0.48
500 mbar (7.5 psi), 3 bar (45 psi), 16 bar (240 psi), 40 bar (600 psi)	±0.20	±0.20	±0.20	±0.35

**Warm-up period**

- 4 to 20 mA HART: < 10 s
- PROFIBUS PA: 6 s
- FOUNDATION Fieldbus: 50 s

## Installation

### General installation instructions

- A position-dependent zero point shift can be corrected directly at the device via operating keys, and also in hazardous areas in the case of devices with external operation.  
Diaphragm seals also shift the zero point, depending on the installation position →  85.
- The housing of the device can be rotated 380°.
- Endress+Hauser offers a mounting bracket for installing the device on pipes or walls.
- Use flushing rings for flange-type and cell-type diaphragm seals if there are suspected medium deposits or blockages at the diaphragm seal connection. The flushing ring can be fitted between the process connection and diaphragm seal. Material buildup in front of the process isolating diaphragm can be flushed away, and the pressure chamber vented, via the two lateral flushing holes.
- When measuring in media containing solids, such as dirty liquids, installing separators and drain valves is useful for capturing and removing sediment.
- Using a three-valve or five-valve manifold allows for easy commissioning, installation and maintenance without interrupting the process.
- General recommendations for the pressure piping can be found in DIN 19210 "Methods for measurement of fluid flow; differential piping for flow measurement devices" or the corresponding national or international standards.
- Install the pressure piping with a continuous gradient of at least 10%.
- When routing the pressure piping outdoors, ensure sufficient anti-freeze protection, e.g. by using pipe heat tracing.
- Point the cable and connector downwards where possible to prevent moisture from entering (e.g. rain or condensation water).

### Measuring arrangement

#### Flow measurement

- The PMD75 is best suited to flow measurement.
- Measuring arrangement for gases: Mount device above the measuring point.
- Measuring arrangement for liquids and vapors: Mount device below the measuring point.
- For flow measurement in vapors, mount the condensate traps at the same level as the tapping point and at the same distance from Deltabar S.

#### Level measurement

The PMD75 and FMD77 are best suited to level measurement in open containers. All Deltabar S devices are suitable for level measurement in closed containers.

Measuring arrangement for level measurement in open containers

- PMD75: Mount device below the lower measuring connection. The negative side is open to atmospheric pressure.
- FMD77: Mount device directly on the vessel. The negative side is open to atmospheric pressure.

Measuring arrangement for level measurement in closed containers and closed containers with superimposed vapor

- PMD75: Mount device below the lower measuring connection. Always connect the negative side above the maximum level via pressure piping.
- FMD77: Mount device directly on the vessel. Always connect the negative side above the maximum level via pressure piping.
- In the case of level measurement in closed vessels with superimposed vapor, a condensate trap ensures the pressure remains constant on the minus side.

#### Pressure measurement

- The PMD75 and FMD78 are best suited to differential pressure measurement.
- Measuring arrangement for gases: Mount device above the measuring point.
- Measuring arrangement for liquids and vapors: Mount device below the measuring point.
- For differential pressure measurement in vapor, mount the condensate traps at the same level as the tapping point and at the same distance from Deltabar S.

### Measuring arrangement for devices with diaphragm seals – FMD77 and FMD78

→  81

### Orientation

The orientation can cause a zero point shift, see →  26.

This position-dependent zero point shift can be corrected directly at the device via the operating key, and also in hazardous areas in the case of devices with external operation (position adjustment).

### Wall and pipe mounting

Endress+Hauser offers a mounting bracket for installing the device on pipes or walls.



If a valve block is used, its dimensions should also be taken into consideration.

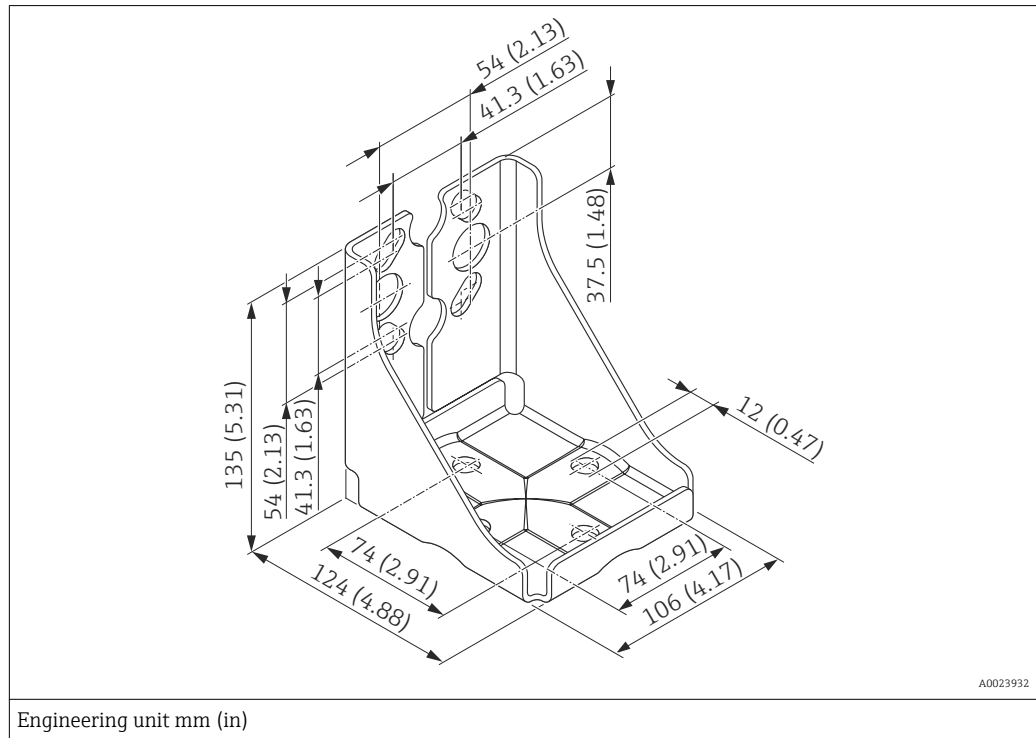

Bracket for wall and pipe mounting including retaining bracket for pipe mounting and two nuts

Materials: Screws and washers A2-70 or A4, bracket and retaining bracket AISI 304 (1.4301). The material of the screws used to secure the device depend on the order code.

Ordering information:

- Product Configurator, order code for "Additional options 2", version "U" or
- Product Configurator, order code for "Accessory enclosed", version "PB"
- Order number for 7/16 UNF: 52024609
- Order number for M10: 52024611
- Order number for M12: 52024610

**"Separate housing" version**

With the "separate housing" version, you are able to mount the housing with the electronics insert at a distance from the measuring point. This version facilitates trouble-free measurement:

- Under particularly difficult measuring conditions (at installation locations that are cramped or difficult to access)
- If rapid cleaning of the measuring point is required and
- If the measuring point is exposed to vibrations
- For compact installations

You can choose between different cable versions:

- PE: 2 m (6.6 ft), 5 m (16 ft) and 10 m (33 ft)
- FEP: 5 m (16 ft).

Ordering information: Product Configurator, order code for "Additional options 2", version "G".

Dimensions →  68

In the case of the "separate housing" version, the sensor is delivered with the process connection and cable ready mounted. The housing and a mounting bracket are enclosed as separate units. The cable is provided with a socket at both ends. These sockets are simply connected to the housing and the sensor.

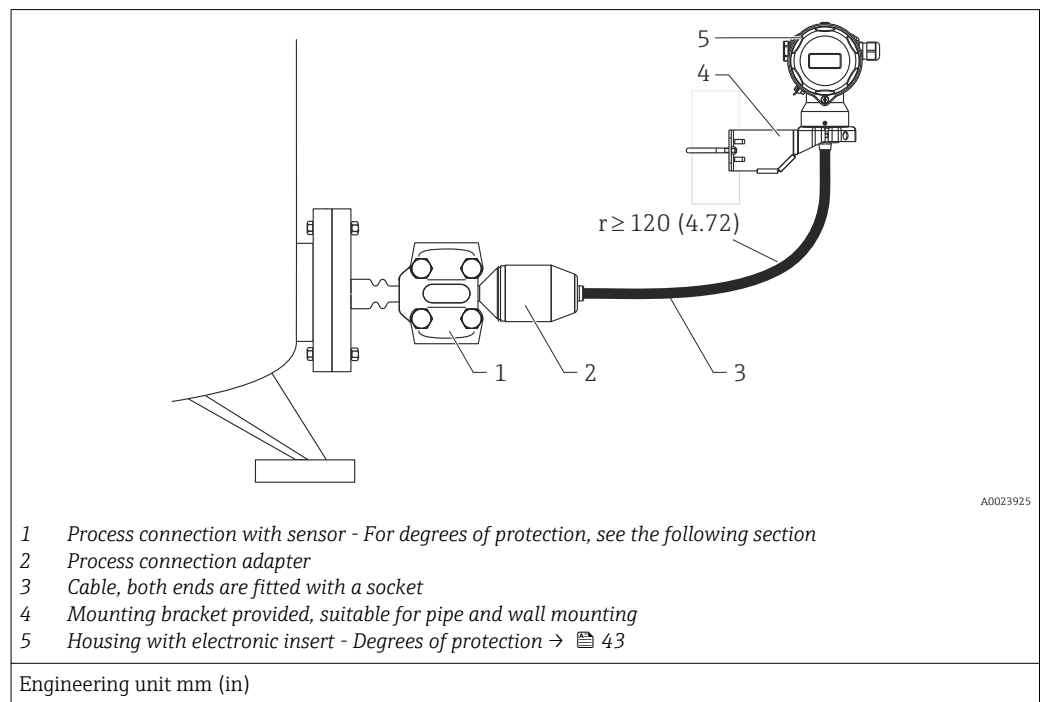

Degree of protection for the process connection and sensor with the use of

- FEP cable:
  - IP 69K
  - IP 66 NEMA 4/6P
  - IP 68 (1.83 mH<sub>2</sub>O for 24 h) NEMA 4/6P
- PE cable:
  - IP 66 NEMA 4/6P
  - IP 68 (1.83 mH<sub>2</sub>O for 24 h) NEMA 4/6P

Technical data of the PE and FEP cable:

- Minimum bending radius: 120 mm (4.72 in)
- Cable extraction force: max. 450 N (101.16 lbf)
- Resistance to UV light

Use in hazardous area:

- Intrinsically safe installations (Ex ia/IS)
- FM/CSA IS: for Div. 1 installation only

Description	Weight
Process connection adapter	0.93 kg (2.05 lb)
Cable	0.05 kg/meter (0.11 lb)

**Reduction of the installation height**

If the separate housing is used, the installation height of the process connection is reduced compared to the dimensions of the standard version.

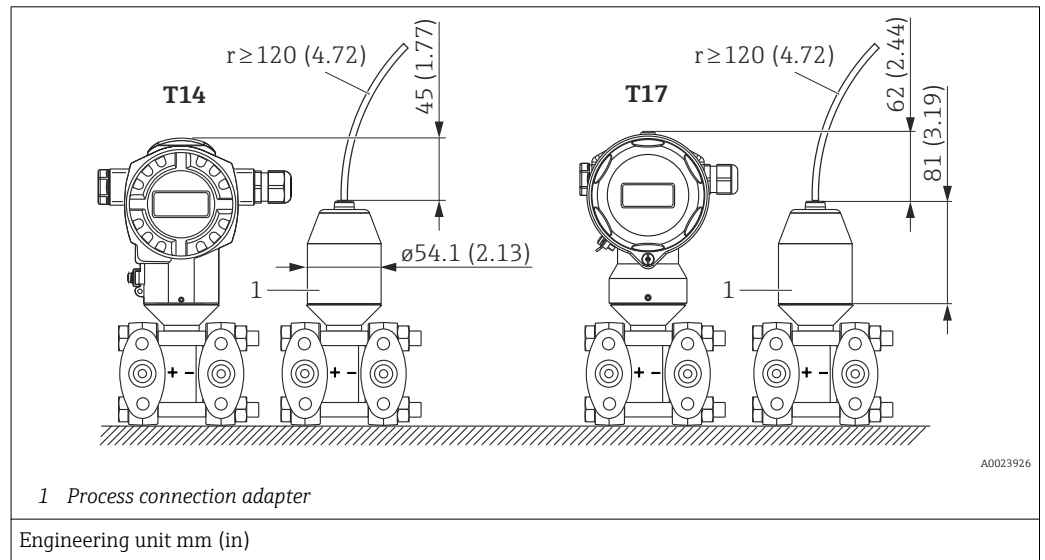

**Turning the housing**

The housing can be rotated up to 380° by loosening the Allen screw.

**The benefits for you**

- Easy mounting due to optimum alignment of housing
- Good, accessible device operation
- Optimum readability of the onsite display (optional).

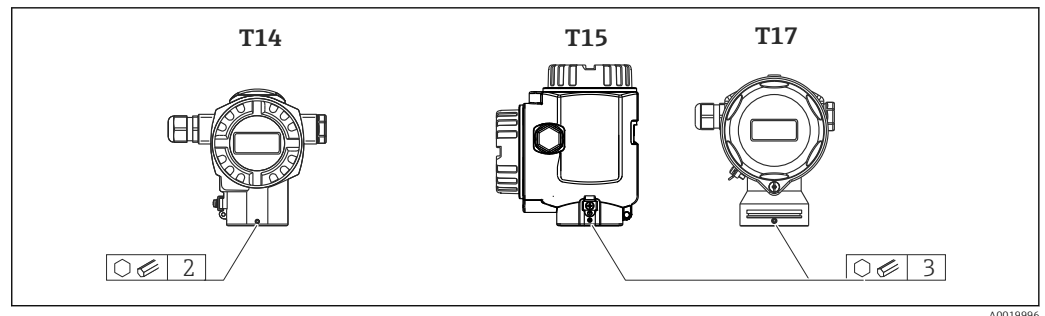

**Oxygen applications**

Oxygen and other gases can react explosively to oils, grease and plastics, such that, among other things, the following precautions must be taken:

- All components of the system, such as measuring devices, must be cleaned in accordance with the BAM (DIN 19247) requirements.
- Dependent on the materials used, a certain maximum temperature and a maximum pressure for oxygen applications must not be exceeded.

The devices suitable for gaseous oxygen applications are listed in the following table with the specification  $p_{\max}$ .

Order code for devices <sup>1)</sup> , cleaned for oxygen applications	$p_{\max}$ for oxygen applications	$T_{\max}$ for oxygen applications
PMD75 - * * * * * K * *	160 bar (2 400 psi)	85 °C (185 °F)
PMD75 - * * * * * 2 * *	160 bar (2 400 psi)	60 °C (140 °F)
PMD75 - * * * * * 3 * *	160 bar (2 400 psi)	60 °C (140 °F)
FMD77 - * * * * * T * F * *	PN of the flange	60 °C (140 °F)
FMD78 - * * * * * 4 * * FMD78 - * * * * * D * *	Depends on filling oil: max. 160 bar (2 400 psi)	85 °C (185 °F)

1) Only devices, not accessories or enclosed accessories.

**Ultrapure gas applications**

Endress+Hauser also offers devices for special applications, such as ultrapure gas, cleaned from oil and grease. No special restrictions regarding the process conditions apply to these devices.

Ordering information:

- PMD75: Product Configurator, order code for "Seal"
- FMD77: Product Configurator, order code for "Process connection low-pressure side; Material; Seal".

**Applications with hydrogen****Liquid applications with hydrogen separation from an electrolyte**

The gold-rhodium coating, which can be ordered in the order code, offers protection only against hydrogen diffusion through the process isolating diaphragm in liquids (e.g. electrolytes or aqueous solutions).

Ordering information:

Product Configurator, order code for "Material of the process isolating diaphragm", option "6".

In gas applications and also in liquid applications with hydrogen separation from an electrolyte with a process temperature > 100 °C (212 °F), **the gold-rhodium coating does not offer** effective protection against hydrogen diffusion through the process isolating diaphragm. The diaphragm requires a pure gold coating. Endress+Hauser offers this product version with a gold coating of 25 µm (984.3 µin) as a **Technical Special Product**.

**Gas applications with hydrogen content**

In the case of a gas application with hydrogen content, the diaphragm requires a pure gold coating. Endress+Hauser offers this product version with a gold coating of 25 µm (984.3 µin) as a **Technical Special Product**.

## Environment

- Ambient temperature range**
- -40 to +85 °C (-40 to +185 °F). Devices for lower temperatures on request.
  - Onsite display: -20 to +70 °C (-4 to +158 °F). Extended temperature operating range with limitations in optical properties, such as display speed and contrast, for example: -40 to +85 °C (-40 to +185 °F)
  - Separate housing: -20 to +60 °C (-4 to +140 °F) (installation without insulation)

**Hazardous areas**

- For devices for use in hazardous areas, see Safety Instructions, Installation or Control Drawing → 97.
- Pressure measuring devices that have the common explosion protection certificates (e.g. ATEX/FM/CSA/ IEC Ex etc.) can be used in hazardous areas with ambient temperatures down to -50 °C (-58 °F). The explosion protection functionality is also guaranteed at ambient temperatures down to -50 °C (-58 °F) .
- The nameplate data is restricted to an ambient temperature of -40 °C (-40 °F) as all of the device's metrological tests are only carried out down to -40 °C (-40 °F). If the device is operated at an ambient temperature below -40 °C (-40 °F) the technical specifications in this document no longer apply. Functional restrictions can be expected.

- Storage temperature range**
- -40 to +90 °C (-40 to +194 °F)
  - Onsite display: -40 to +85 °C (-40 to +185 °F)
  - Separate housing: -40 to +60 °C (-40 to +140 °F)

- Degree of protection**
- Housing: → 43
  - Separate housing: → 33

**Climate class** Class 4K4H (air temperature: -20 to +55 °C (-4 to +131 °F), relative humidity: 4 to 100 %) fulfilled as per DIN EN 60721-3-4 (condensation possible).

- Electromagnetic compatibility**
- Electromagnetic compatibility as per EN 61326 and NAMUR recommendation EMC (NE21).
  - With enhanced immunity against electromagnetic fields as per EN 61000-4-3: 30 V/m with closed cover (for devices with T14or T15 housing)
  - Maximum deviation: < 0.5 % of span
  - All EMC measurements were performed with a turn down (TD) = 2:1.

For further details refer to the Declaration of Conformity. A description of how to download this document is provided in the next section.

**Downloading the Declaration of Conformity**

<http://www.endress.com/en/download>

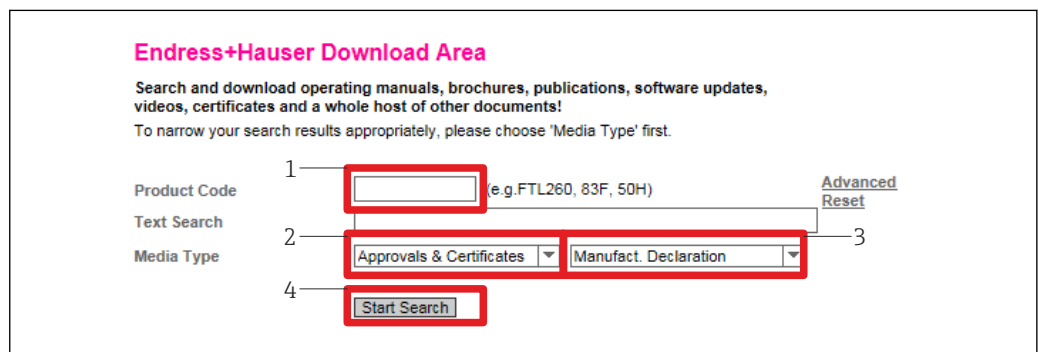

A0027319-EN

1. Enter the required product code
2. Select "Approvals & Certificates"
3. Select "Manufact. Declaration"
4. Click on "Start Search"

The available downloads are displayed.

## Vibration resistance

Device/accessory	Measuring cells	Housing	Test standard	Vibration resistance
PMD75	10 mbar (0.15 psi), 30 mbar (0.45 psi)	T14 stainless steel T15 aluminum T17 aluminum	IEC 61298-3	Guaranteed for 10 to 38 Hz: ±0.35 mm (0.0138 in); 38 to 2000 Hz: 2 g in all 3 planes
		T14 aluminum	IEC 61298-3	Guaranteed for 10 to 60 Hz: ±0.21 mm (0.0083 in); 60 to 2000 Hz: 3 g in all 3 planes
	≥ 100 mbar (1.5 psi)	T14 stainless steel T15 aluminum	IEC 61298-3	Guaranteed for 10 to 38 Hz: ±0.35 mm (0.0138 in); 38 to 2000 Hz: 2 g in all 3 planes
		T14 aluminum	IEC 61298-3	Guaranteed for 10 to 60 Hz: ±0.35 mm (0.0138 in); 60 to 2000 Hz: 5 g in all 3 planes
With mounting bracket	All	All	IEC 61298-3	Guaranteed for 10 to 60 Hz: ±0.15 mm (0.0059 in); 60 to 500 Hz: 2 g in all 3 planes
FMD77	All	All	IEC 61298-3:1998	Guaranteed for 10 to 60 Hz: ±0.075 mm (0.0030 in); 60 to 150 Hz: 1 g in all 3 planes

## Process

### Process temperature limits (temperature at transmitter)

Device	Process connection material		
	316L / alloy C276	C22.8	PVDF
PMD75	-40 to +85 °C (-40 to +185 °F)	-10 to +85 °C (+14 to +185 °F)	-
FMD78	Dependent on the diaphragm seal and filling oil: up to +400 °C (752 °F)		
FMD77	Dependent on the design (see following table) and dependent on the diaphragm seal and filling oil (→ ☰ 83): up to +400 °C (752 °F)		

Design	Temperature isolator	Temperature	Option <sup>1)</sup>
Transmitter horizontal	long	400 °C (752 °F)	MA
Transmitter vertical	long	300 °C (572 °F)	MB
Transmitter horizontal	short	200 °C (392 °F)	MC
Transmitter vertical	short	200 °C (392 °F)	MD
U-bracket, Transmitter horizontal (for devices which require a CRN approval)	-	400 °C (752 °F)	<sup>2)</sup>
Compact version, Transmitter vertical	-	260 °C (500 °F)	5, 6, 7, 8

- 1) Product Configurator, order code for "Process connection"
- 2) In combination with CSA approval

- i** For oxygen applications, → ☰ 36, please comply with the "Oxygen applications" section.
- PMD75 and FMD78: Observe the process temperature range of the seal. See also the following section "Process temperature range, seals".
- FMD77 and FMD78:
  - Please observe the temperature application limits of the diaphragm seal oil. → ☰ 83, "Diaphragm seal filling oils" section.
  - Please observe the maximum gauge pressure and maximum temperature.

### Devices with PTFE-coated process isolating diaphragm

#### NOTICE

#### Incorrect use of the PTFE foil will destroy the device!

- ▶ The PTFE foil is designed to protect the unit against abrasion. It does not provide protection against corrosive media.

See the graphic below for the application range of the 0.25 mm (0.01 in) PTFE foil on an AISI 316L (1.4404/1.4435) process isolating diaphragm:

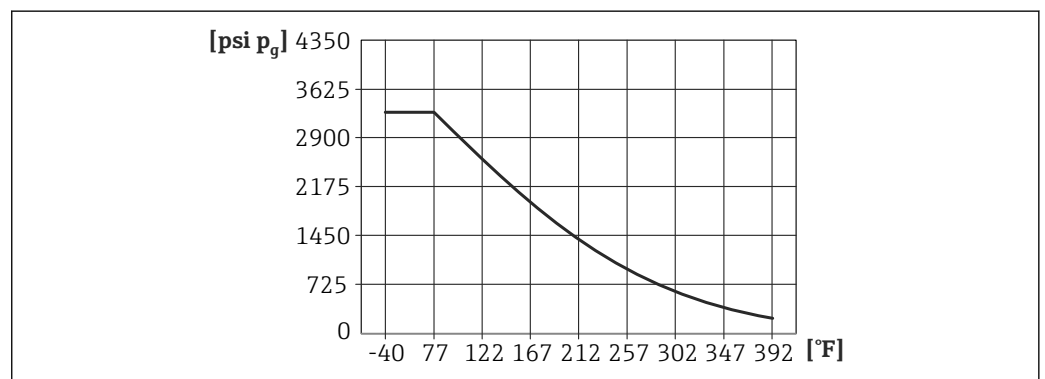

A0026949-EN

- i** For vacuum applications:  $p_{abs} \leq 1 \text{ bar (14.5 psi)}$  to  $0.05 \text{ bar (0.725 psi)}$  to  $+150 \text{ °C (302 °F)}$  max.

**Process temperature range, seals****PMD75**

Seal	Process temperature range <sup>1)</sup>	Option <sup>2)</sup>
FKM Viton	-20 to +85 °C (-4 to +185 °F)	A
PTFE	-40 to +85 °C (-40 to +185 °F)	C
NBR	-20 to +85 °C (-4 to +185 °F)	F
Copper	-40 to +85 °C (-40 to +185 °F)	H
Copper, cleaned for oxygen service	-20 to +85 °C (-4 to +185 °F)	K
FKM Viton, cleaned from oil and grease	-10 to +85 °C (+14 to +185 °F)	1
FKM Viton, cleaned for oxygen service	-10 to +60 °C (+14 to +140 °F)	2
PTFE, cleaned for oxygen applications	-20 to +60 °C (-4 to +140 °F)	3

- 1) Lower temperatures on request  
 2) Product Configurator, order code for "Seal"

**FMD77 (with diaphragm seal)**



Seal on the LP side (-)	Process temperature range <sup>1)</sup>	OPL bar (psi)	PN bar (psi)	Option <sup>2)</sup>
FKM Viton	-20 to +85 °C (-4 to +185 °F)	See the "Measuring range" section "FMD77, FMD78, PMD75: Option PN 160/16 MPa/2400 psi" →  11.		B, D, F, U
PTFE	-40 to +85 °C (-40 to +185 °F)			H, J
EPDM	-40 to +85 °C (-40 to +185 °F)			K, L
FKM Viton, cleaned from oil and grease	-10 to +85 °C (+14 to +185 °F)			S
FKM Viton, cleaned for oxygen service	-10 to +60 °C (+14 to +140 °F)			T
Kalrez, Compound 6375	0 to +5 °C (+32 to +41 °F)	44...49 (660...735)	29...33 (435...495)	M, N
	+5 to +10 °C (+41 to +50 °F)	49...160 (735...2400)	33...107 (495...1605)	
	+10 to +85 °C (+50 to +185 °F)	160 (2400)	107 (1605)	
Chemraz, Compound 505	-10 to +25 °C (+14 to +77 °F)	130...160 (1950...2400)	87...107 (1305...1605)	P, Q
	+25 to +85 °C (+77 to +185 °F)	160 (2400)	107 (1605)	

- 1) Lower temperatures on request  
 2) Product Configurator, order code for "Process connection, LP side; Seal."

## Pressure specifications

**⚠ WARNING**

**The maximum pressure for the measuring device depends on the lowest-rated element with regard to pressure.**

- ▶ For pressure specifications, see the "Measuring range" section and the "Mechanical construction" section.
- ▶ The measuring device must be operated only within the specified limits!
- ▶ The MWP (maximum working pressure) is specified on the nameplate of the individual sensor module. This value refers to a reference temperature of +20 °C (+68 °F), or +38 °C (+100 °F) for ASME flanges, and can be present at the device for an unlimited period. Observe the pressure-temperature dependency of the MWP.
- ▶ Please refer to the standards EN 1092-1: 2001 Tab. 18 for the pressure values permitted in the case of higher temperatures. (With regard to their stability-temperature property, the materials 1.4435 and 1.4404 are grouped together under 13E0 in EN 1092-1 Tab. 18. The chemical composition of the two materials can be identical). // ASME B 16.5a – 1998 Tab. 2-2.2 F316 // ASME B 16.5a – 1998 Tab. 2.3.8 N10276 // JIS B 2220
- ▶ The test pressure corresponds to the overload limit of the individual sensors (over pressure limit OPL = 1.5 x MWP ) and may be applied only for a limited period of time to prevent any lasting damage.
- ▶ The Pressure Equipment Directive (EC Directive 97/23/EC) uses the abbreviation "PS". The abbreviation "PS" corresponds to the MWP (maximum working pressure ) of the measuring device.
- ▶ In the case of sensor range and process connections where the over pressure limit (OPL) of the process connection is smaller than the nominal value of the sensor, the device is set at the factory, at the very maximum, to the OPL value of the process connection. If you want to use the entire sensor range, select a process connection with a higher OPL value (1.5 x PN; MWP = PN)
- ▶ In oxygen applications, the values for  $p_{\max}$  and  $T_{\max}$  for oxygen applications may not be exceeded →  36.
- ▶ Steam hammering must be avoided. Steam hammering can cause zero point drifts. Recommendation: Residue (water droplets or condensation) may remain on the process isolating diaphragm following CIP cleaning and can result in local steam hammering the next time steam cleaning takes place. In practice, drying the process isolating diaphragm (e.g. by blowing) has proved to prevent steam hammering.
- ▶ For the PMD75, the MWP applies to the temperature ranges specified in the "Ambient temperature range" →  37 and "Process temperature limits" sections.

## Mechanical construction

### Device height

The device height is calculated from

- the height of the housing
- the height of optional mounted parts such as temperature isolators or capillaries
- the height of the relevant process connection.

The individual heights of the components can be found in the following sections. To calculate the device height, simply add up the individual heights of the components. If necessary, the installation space (the space used to install the device) must also be taken into account. You can use the following table for this:

#### PMD75

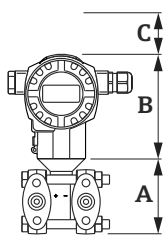
Description	Item	Dimension	Example
Side flanges	(A)	85 mm (3.35 in)	
Height of housing	(B)	→ 43 ff.	
Installation space	(C)	-	
Device height			

A0023927

#### FMD77

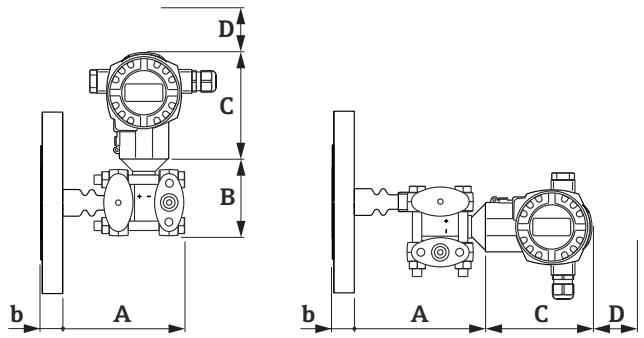
Description	Item	Dimension	Example
Mounted parts	(A)	→ 49	
Side flanges	(B)	85 mm (3.35 in)	
Height of housing	(C)	→ 43 ff.	
Installation space	(D)	-	
Process connections	(b)	→ 45	
Device height			

A0025880

#### FMD78

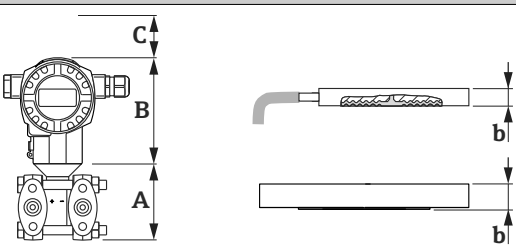
Description	Item	Dimension	Example
Side flanges	(A)	85 mm (3.35 in)	
Height of housing	(B)	→ 43 ff.	
Installation space	(C)	-	
Process connections	(b)	→ 45	
Device height			

A0025881

**T14 housing, optional display on the side**

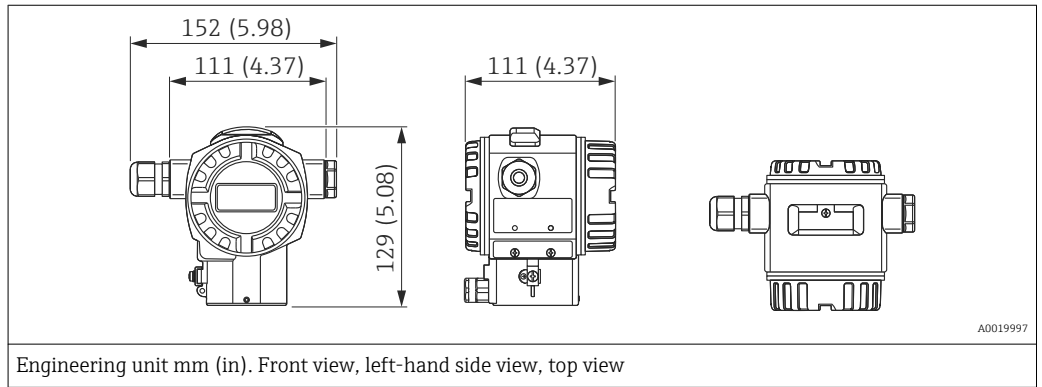

Material		Degree of protection	Cable entry	Weight in kg (lb)		Option <sup>1)</sup>
Housing	Cover seal			with display	without display	
Aluminum	EPDM	IP66/67 NEMA 6P	M20 gland	1.2 (2.65)	1.1 (2.43)	A
		IP66/67 NEMA 6P	G ½" thread			B
		IP66/67 NEMA 6P	NPT ½" thread			C
		IP66/67 NEMA 6P	M12 plug			D
		IP66/67 NEMA 6P	7/8" plug			E
		IP65 NEMA 4	HAN7D plug 90 degrees			F
316L	EPDM	IP66/67 NEMA 6P	M20 gland	2.1 (4.63)	2.0 (4.41)	1
		IP66/67 NEMA 6P	G ½" thread			2
		IP66/67 NEMA 6P	NPT ½" thread			3
		IP66/67 NEMA 6P	M12 plug			4
		IP66/67 NEMA 6P	7/8" plug			5
		IP65 NEMA 4	HAN7D plug 90 degrees			6
	FVMQ	IP66/67 NEMA 6P	M20 gland	7		
	FVMQ	IP66/67 NEMA 6P	NPT ½" thread	8		

1) Product Configurator, order code for "Housing, cover seal, cable entry, degree of protection"

**T15 housing, optional display on the top**

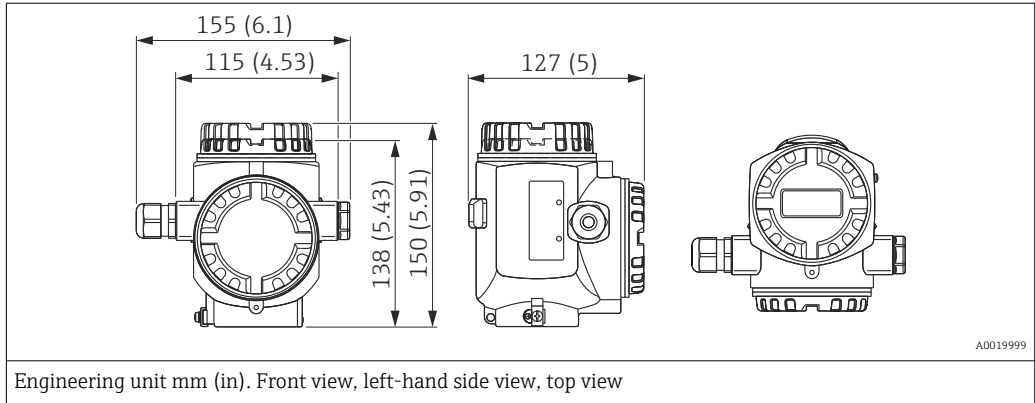

Material		Degree of protection	Cable entry	Weight in kg (lb)		Option <sup>1)</sup>
Housing	Cover seal			with display	without display	
Aluminum	EPDM	IP66/67 NEMA 6P	M20 gland	1.8 (3.97)	1.7 (3.75)	J
		IP66/67 NEMA 6P	G ½" thread			K
		IP66/67 NEMA 6P	NPT ½" thread			L
		IP66/67 NEMA 6P	M12 plug			M
		IP66/67 NEMA 6P	7/8" plug			N
		IP65 NEMA 4	HAN7D plug 90 degrees			P

1) Product Configurator, order code for "Housing, cover seal, cable entry, degree of protection"

**T17 housing (hygienic), optional display on the side**

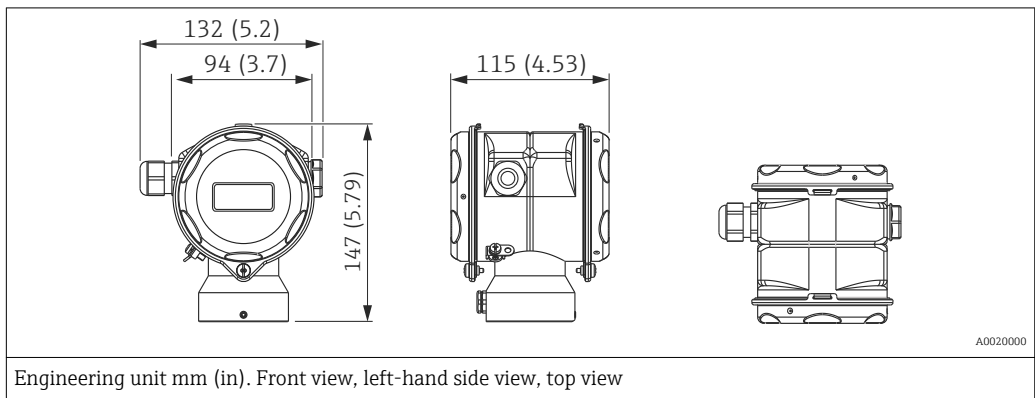

Material		Degree of protection <sup>1)</sup>	Cable entry	Weight in kg (lb)		Option <sup>2)</sup>
Housing	Cover seal			with display	without display	
316L	EPDM	IP66/68 NEMA 6P	M20 gland	1.2 (2.65)	1.1 (2.43)	R
		IP66/68 NEMA 6P	G ½" thread			S
		IP66/68 NEMA 6P	NPT ½" thread			T
		IP66/68 NEMA 6P	M12 plug			U
		IP66/68 NEMA 6P	7/8" plug			V

1) Degree of protection IP 68: 1.83 mH<sub>2</sub>O for 24 h

2) Product Configurator, order code for "Housing, cover seal, cable entry, degree of protection"

Process connections PMD75 Oval flange, connection 1/4-18 NPT or RC 1/4

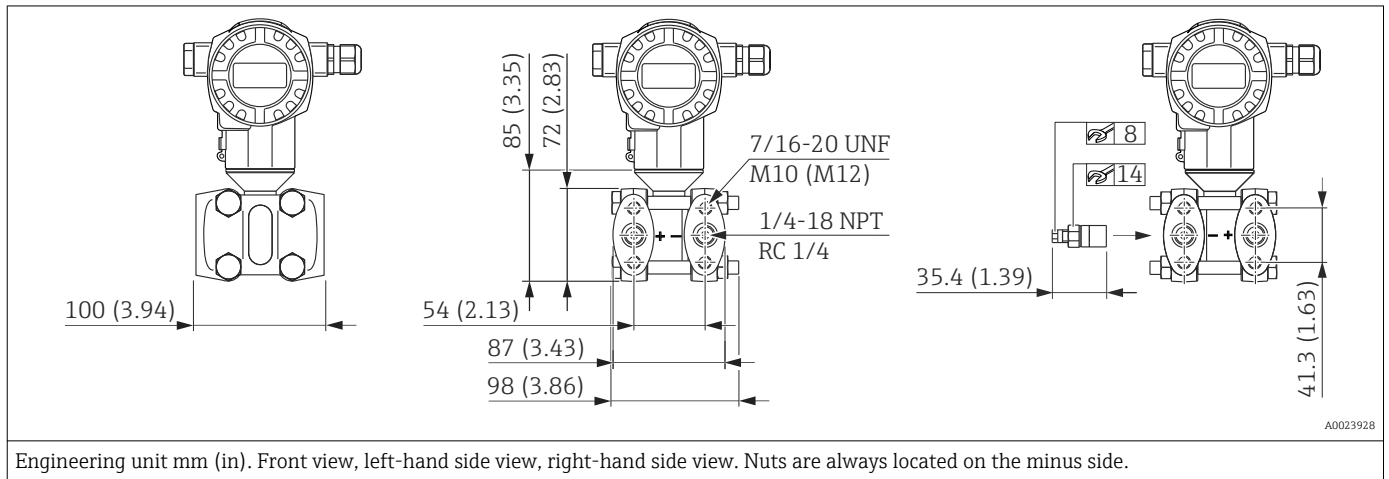

Connection	Mounting	Material	Accessories	Weight <sup>1)</sup>	Option <sup>2)</sup>
				kg (lbs)	
1/4-18 NPT IEC 61518	7/16-20 UNF	Steel C 22.8 (1.0460/Zn5) <sup>3)</sup>	Including 2 vent valves AISI 316L (1.4404)	4.2 (9.26)	B
1/4-18 NPT IEC 61518	7/16-20 UNF	AISI 316L (1.4408) AISI 316L (1.4404) <sup>4)</sup>			D
1/4-18 NPT IEC 61518	7/16-20 UNF	Alloy C276 (2.4819)	Vent valves Alloy C276 (2.4819) <sup>5)</sup>	4.5 (9.92)	F
RC 1/4	7/16-20 UNF	AISI 316L (1.4408) AISI 316L (1.4404) <sup>4)</sup>	Including 2 vent valves AISI 316L (1.4404)	4.2 (9.26)	U
1/4-18 NPT IEC 61518	<ul style="list-style-type: none"> <li>■ PN 160: M10</li> <li>■ PN 420: M12</li> </ul>	Steel C 22.8 (1.0460/Zn5) <sup>3)</sup>			1
1/4-18 NPT IEC 61518	<ul style="list-style-type: none"> <li>■ PN 160: M10</li> <li>■ PN 420: M12</li> </ul>	AISI 316L (1.4404)			2
1/4-18 NPT IEC 61518	<ul style="list-style-type: none"> <li>■ PN 160: M10</li> <li>■ PN 420: M12</li> </ul>	Alloy C276 (2.4819)	Vent valves Alloy C276 (2.4819) <sup>5)</sup>	4.5 (9.92)	3

- 1) Weight of process connections without vent valves with 10 mbar (0.15 psi) or 30 mbar (0.45 psi) measuring cell, process connections without vent valves with measuring cells  $\geq 100$  mbar (1.5 psi) weigh approx. 800 g (28.22 oz) less.
- 2) Product Configurator, order code for "Process connection"
- 3) The C22.8 side flanges are coated with anti-corrosion protection (zinc, chrome). In order to prevent hydrogen diffusion through the diaphragm, Endress+Hauser recommends to use side flanges made out of 316L for application with water. Hydrogen diffusion through the diaphragm leads to measurement errors, or in extreme cases to a device failure.
- 4) For devices with CSA approval: Product Configurator, order code for "Approval", options D, E, F, U, V, W and X
- 5) Product Configurator, order code for "Additional options 2"

Process connections PMD75 Oval flange, connection 1/4-18 NPT or RC 1/4, with side vent

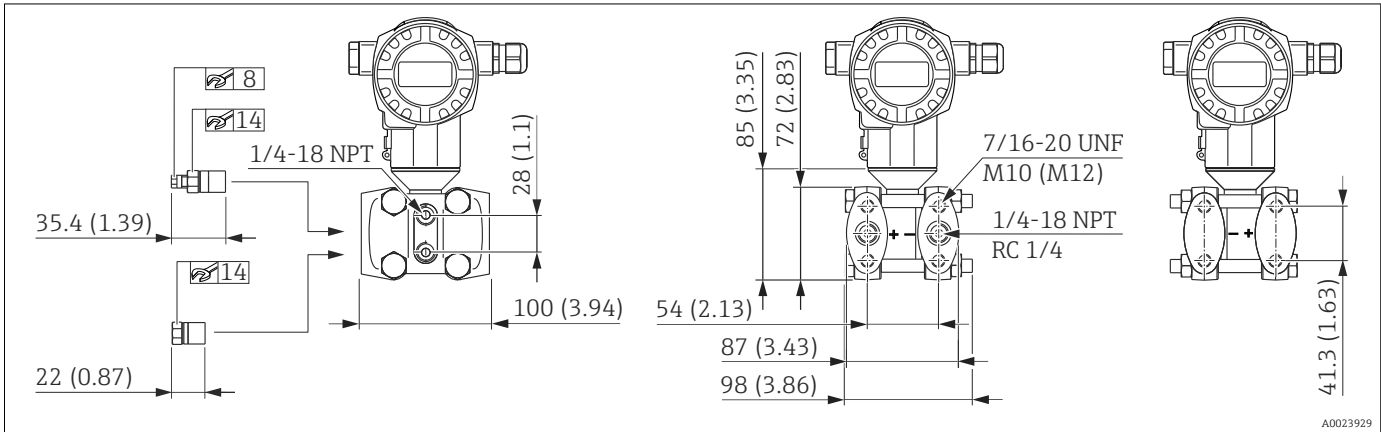

Engineering unit mm (in). Front view, left-hand side view, right-hand side view. Nuts are always located on the minus side.

Connection	Mounting	Material	Accessories	Weight <sup>1)</sup>	Option <sup>2)</sup>
				kg (lbs)	
1/4-18 NPT IEC 61518	7/16-20 UNF	Steel C 22.8 (1.0460/Zn5) <sup>3)</sup>	Including 4 locking screws and 2 vent valves AISI 316L (1.4404)	4.2 (9.26)	C
1/4-18 NPT IEC 61518	7/16-20 UNF	AISI 316L (1.4408) AISI 316L (1.4404) <sup>4)</sup>			E
1/4-18 NPT IEC 61518	7/16-20 UNF	Alloy C276 (2.4819)	Vent valves Alloy C276 (2.4819) <sup>5)</sup>	4.5 (9.92)	H
RC 1/4	7/16-20 UNF	AISI 316L (1.4408) AISI 316L (1.4404) <sup>4)</sup>	Including 4 locking screws and 2 vent valves AISI 316L (1.4404)	4.2 (9.26)	V

- 1) Weight of process connections without vent valves with 10 mbar (0.15 psi) or 30 mbar (0.45 psi) measuring cell, process connections without vent valves with measuring cells  $\geq 100$  mbar (1.5 psi) weigh approx. 800 g (28.22 oz) less.
- 2) Product Configurator, order code for "Process connection"
- 3) The C22.8 side flanges are coated with anti-corrosion protection (zinc, chrome). In order to prevent hydrogen diffusion through the diaphragm, Endress+Hauser recommends to use side flanges made out of 316L for application with water. Hydrogen diffusion through the diaphragm leads to measurement errors, or in extreme cases to a device failure.
- 4) For devices with CSA approval: Product Configurator, order code for "Approval", options D, E, F, U, V, W and X
- 5) Product Configurator, order code for "Additional options 2"

**Process connections PMD75 Oval flange, prepared for diaphragm seal mount**

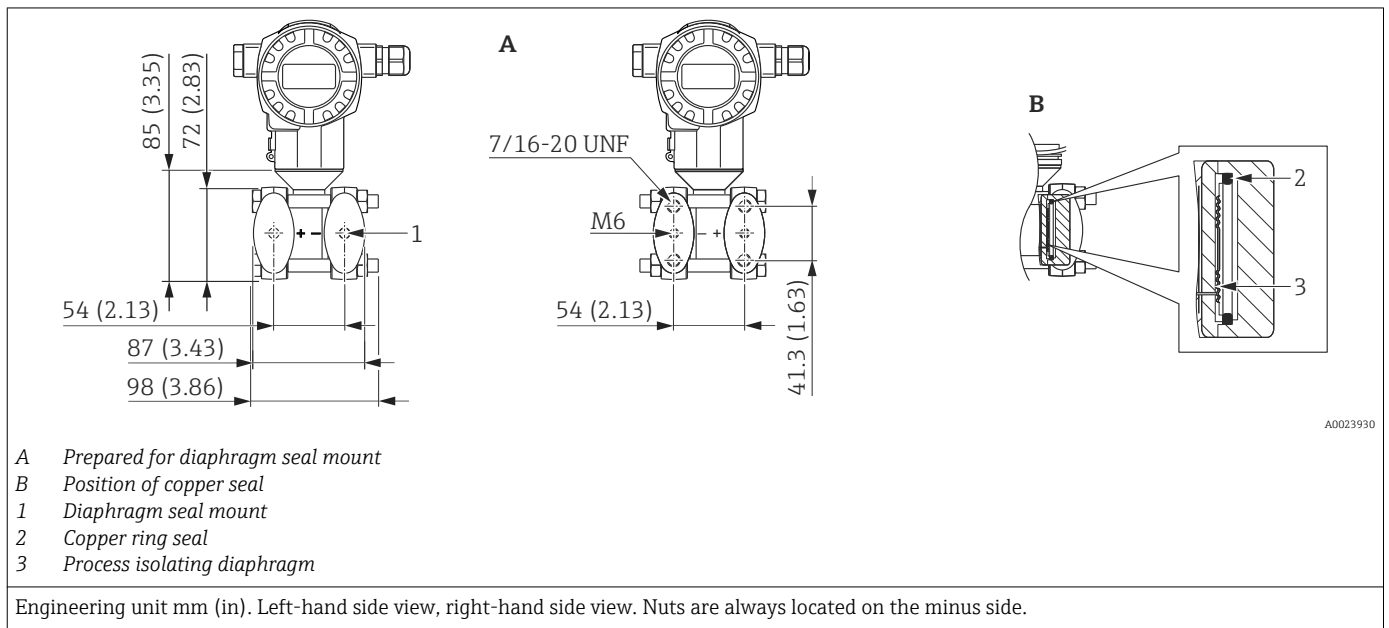

Material	Option <sup>1)</sup>
AISI 316L (1.4408)	W
AISI 316L (1.4404) <sup>2)</sup>	

- 1) Product Configurator, order code for "Process connection"
- 2) For devices with CSA approval: Product Configurator, order code for "Approval", options D, E, F, U, V, W and X

**Mounting on valve manifold**

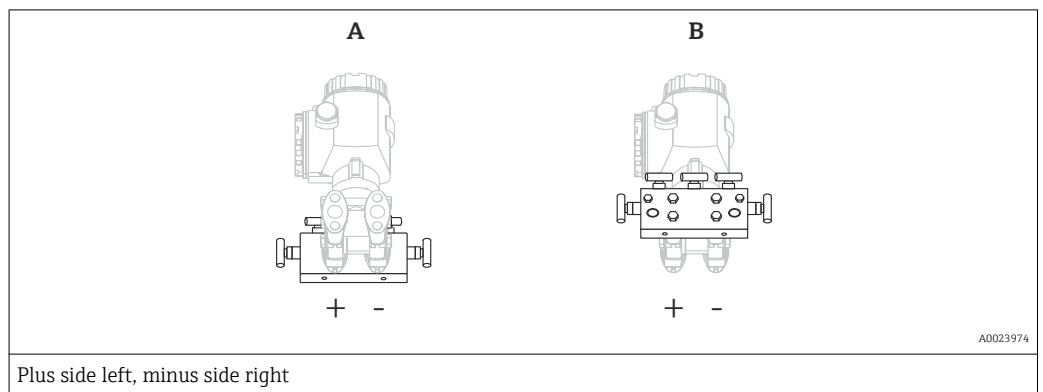

Item	Description	Option
A	Mounting from above	V <sup>1)</sup> / NV <sup>2)</sup>
B	Mounting from below	W <sup>1)</sup> /NW <sup>2)</sup>

- 1) Product Configurator, order code for "Additional options 1"
- 2) Product Configurator order code for "Accessory mounted"

FMD77 - Overview

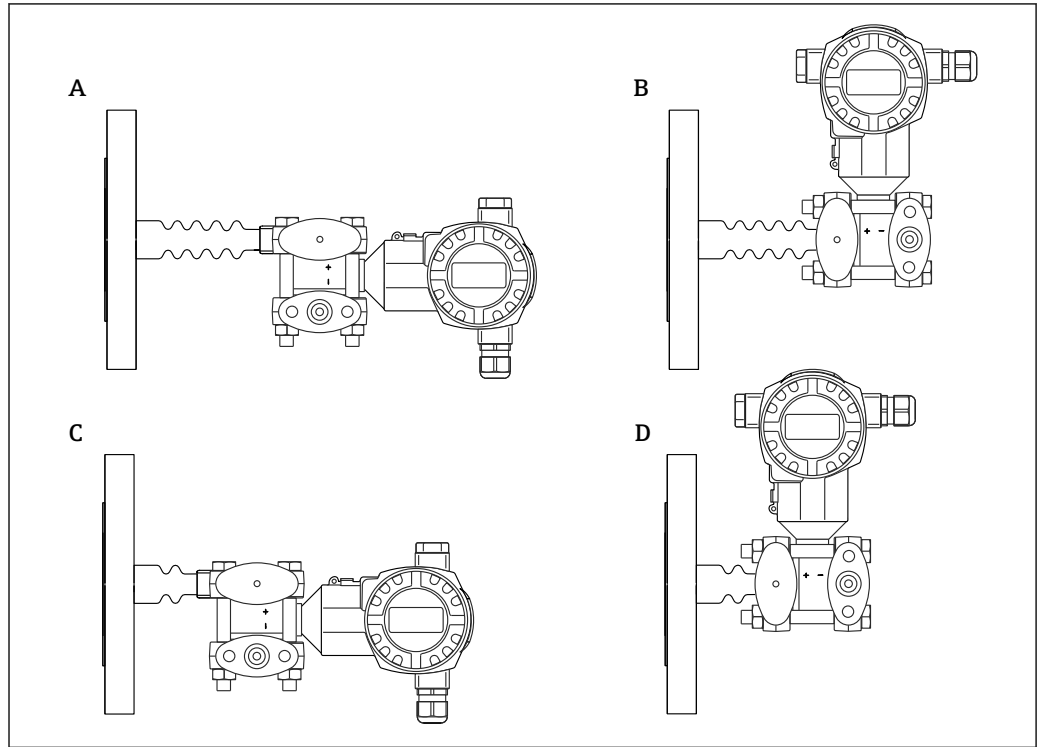

A0025157

Item	Design	Temperature isolator	Page	Option <sup>1)</sup>
A	Transmitter horizontal	long	→ 49	MA <sup>2)</sup>
B	Transmitter vertical	long	→ 49	MB
C	Transmitter horizontal	short	→ 49	MC
D	Transmitter vertical	short	→ 49	MD

1) Product Configurator, order code for "Design; Temperature isolator"

2) Standard

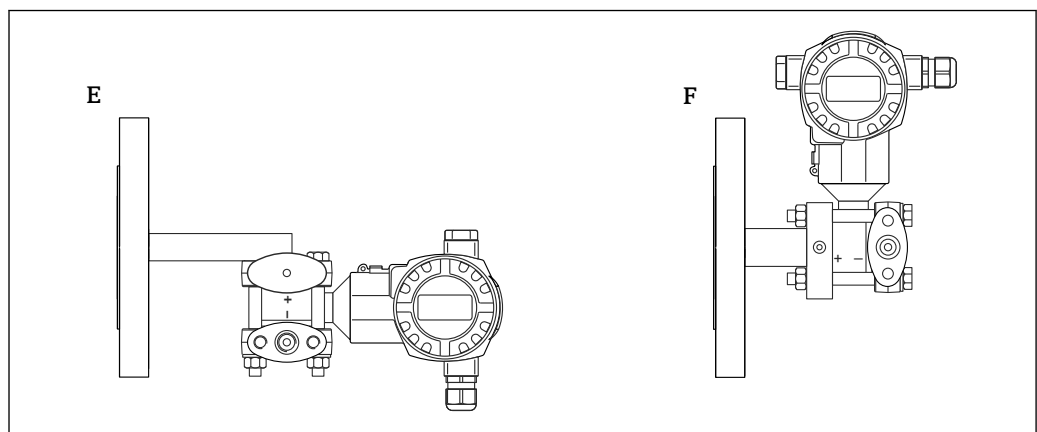

A0025252

Item	Design	Page	Option <sup>1)</sup>
E	U-bracket, Transmitter horizontal (for devices which require a CRN approval)	→ 50	<sup>2)</sup>
F	Compact version, Transmitter vertical	→ 50	5, 6, 7, 8

1) Product Configurator, order code for "Process connection"

2) In combination with CSA approval.

**Process connections FMD77  
with diaphragm seal, high-  
pressure side**

**Device with long temperature isolator**

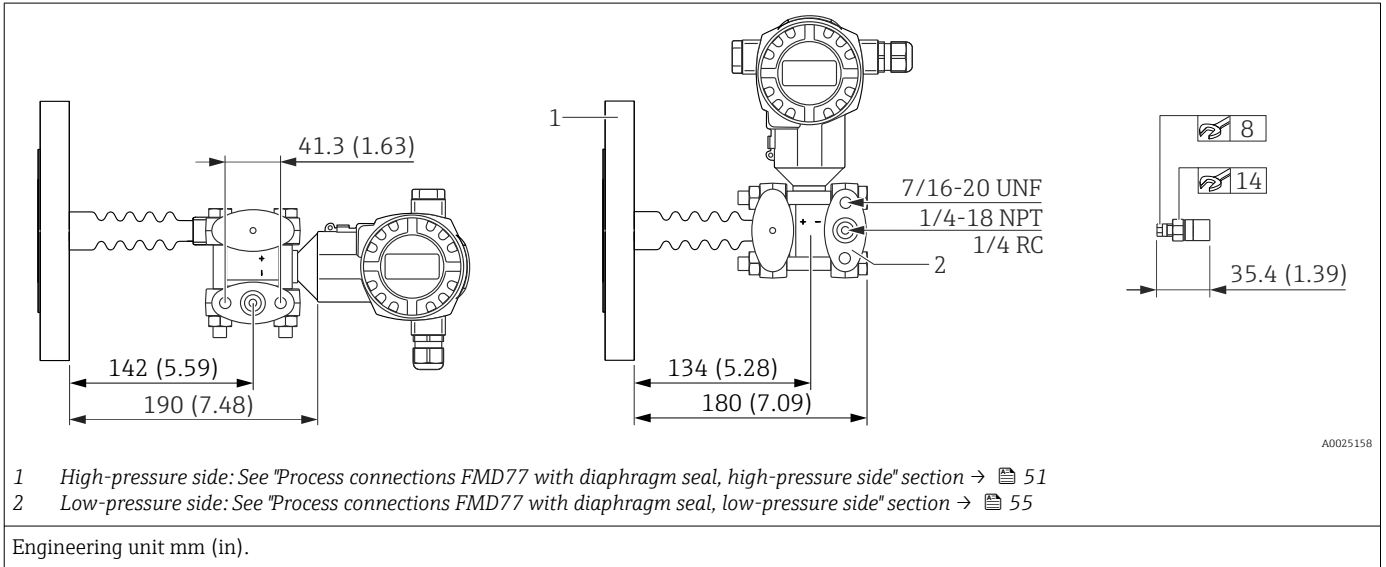

**Device with short temperature isolator**

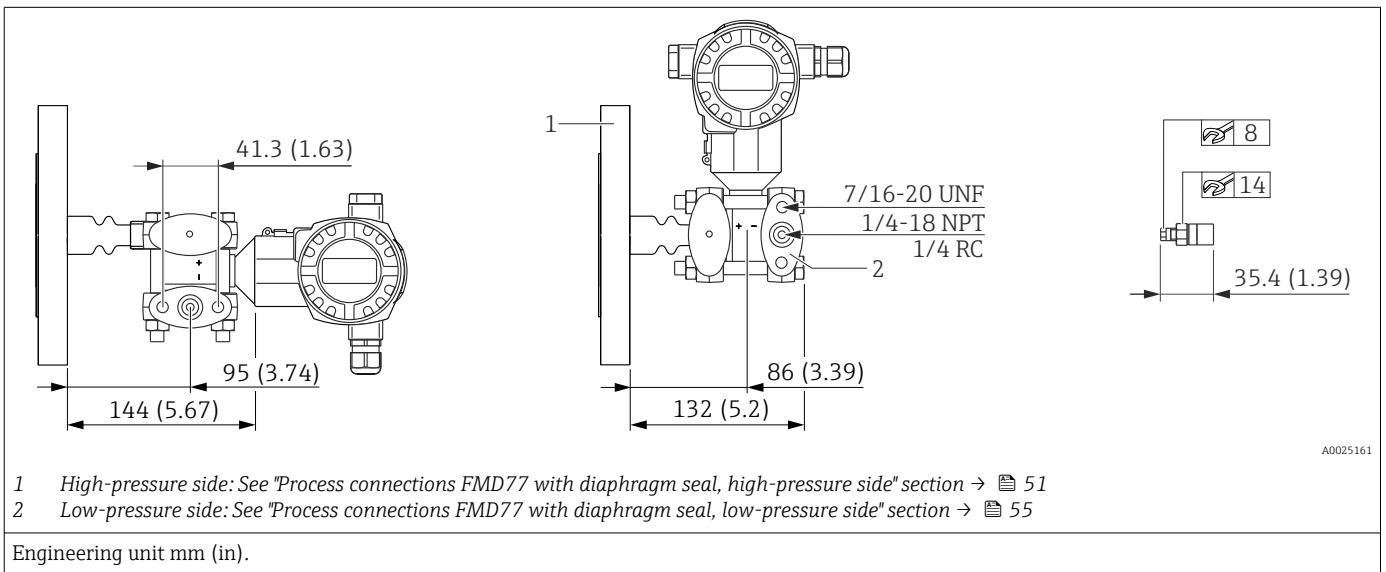

**Process connections FMD77  
with diaphragm seal, high-  
pressure side**

**U-bracket with CRN approval**

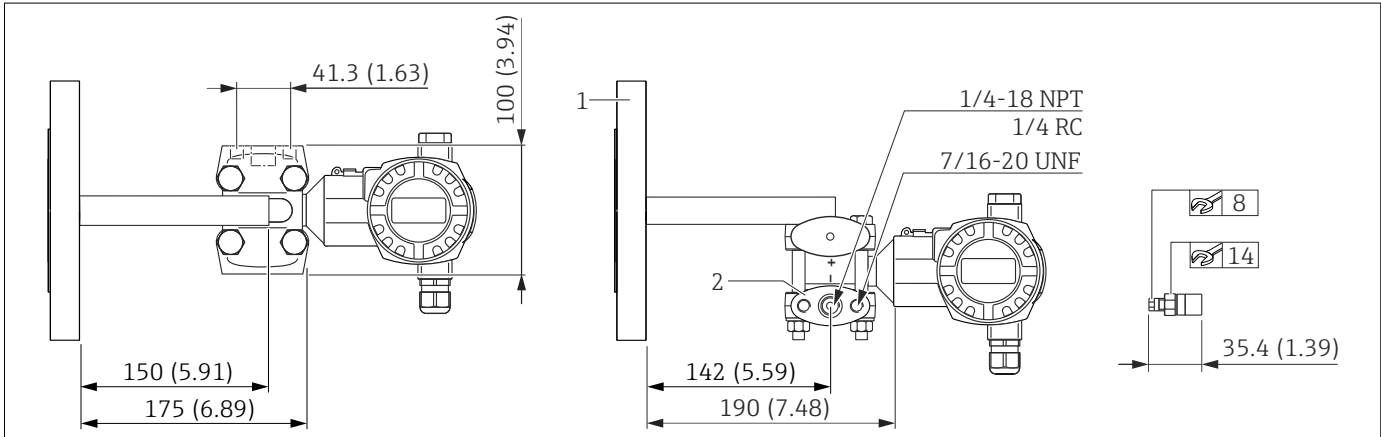

- 1 High-pressure side: See "Process connections FMD77 with diaphragm seal, high-pressure side" section → 51  
 2 Low-pressure side: See "Process connections FMD77 with diaphragm seal, low-pressure side" section → 55

Engineering unit mm (in).

**Compact version**

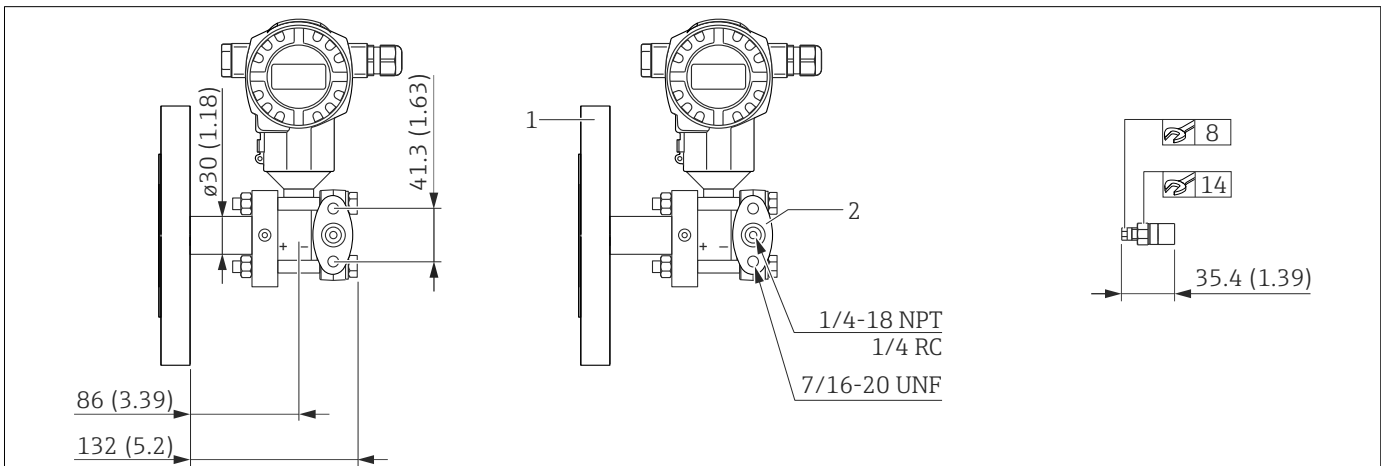

- 1 High-pressure side: See "Process connections FMD77 with diaphragm seal, high-pressure side" section → 51  
 2 Low-pressure side: See "Process connections FMD77 with diaphragm seal, low-pressure side" section → 55

Engineering unit mm (in).

**Process connections FMD77 with diaphragm seal, high-pressure side**



- The following drawings are drawings that illustrate how the system works in principle. In other words, the dimensions of a diaphragm seal supplied can deviate from the dimensions given in this document.
- With the use of high-temperature oils the design can deviate strongly.
- Observe the "Planning instructions, diaphragm seal systems" section → 81
- For further information please contact your local Endress+Hauser Sales Center.

**EN/DIN flanges, connection dimensions in accordance with EN 1092-1/DIN 2527**

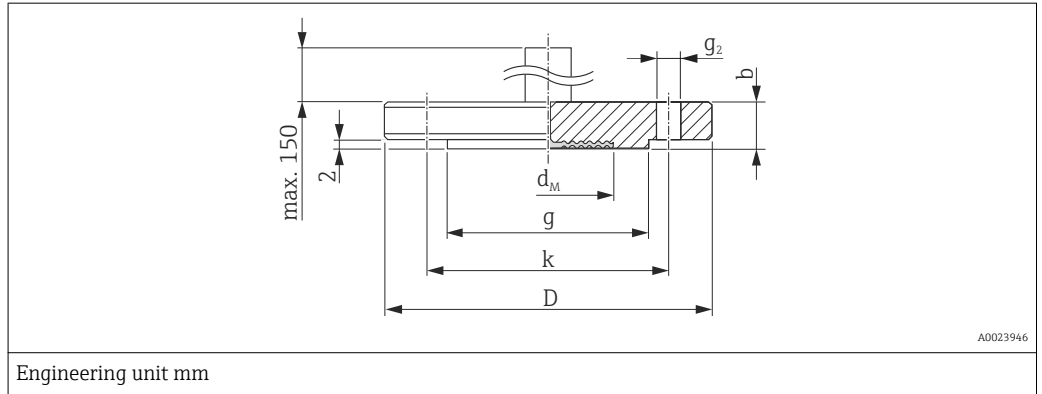

Flange <sup>1) 2) 3)</sup>						Boltholes			Diaphragm seal		Option <sup>4)</sup>
Nominal diameter	Nominal pressure	Shape <sup>5)</sup>	D	Thickness	Raised face	Number	g <sub>2</sub>	Hole circle	Max. diameter process isolating diaphragm	Weight	
				b	g			k			
			[mm]	[mm]	[mm]			[mm]	[mm]	[mm]	
DN 50	PN 10-40	B1 (D)	165	20	102	4	18	125	59	3.0 (6.62)	A
DN 80	PN 10-40	B1 (D)	200	24	138	8	18	160	89	5.2 (11.47)	B
DN 100	PN 10-16	B1 (C)	220	20	-	8	18	180	89	4.8 (10.58)	F
DN 100	PN 25-40	B1 (D)	235	24	162	8	22	190	89	6.7 (14.77)	G

- 1) Material: AISI 316L
- 2) The surface roughness of the wetted surfaces, including the raised face of flanges (all standards) made of Alloy C276, Monel, tantalum, rhodium-gold or PTFE is  $R_a < 0.8 \mu\text{m}$  (31.5  $\mu\text{in}$ ). Lower surface roughness on request.
- 3) The flange raised face is made of the same material as the process isolating diaphragm.
- 4) Product Configurator, order code for "Process connection"
- 5) Name as per DIN 2527 provided in brackets

EN/DIN flanges with barrel (extended diaphragm seal), connection dimensions in accordance with EN 1092-1/DIN 2527

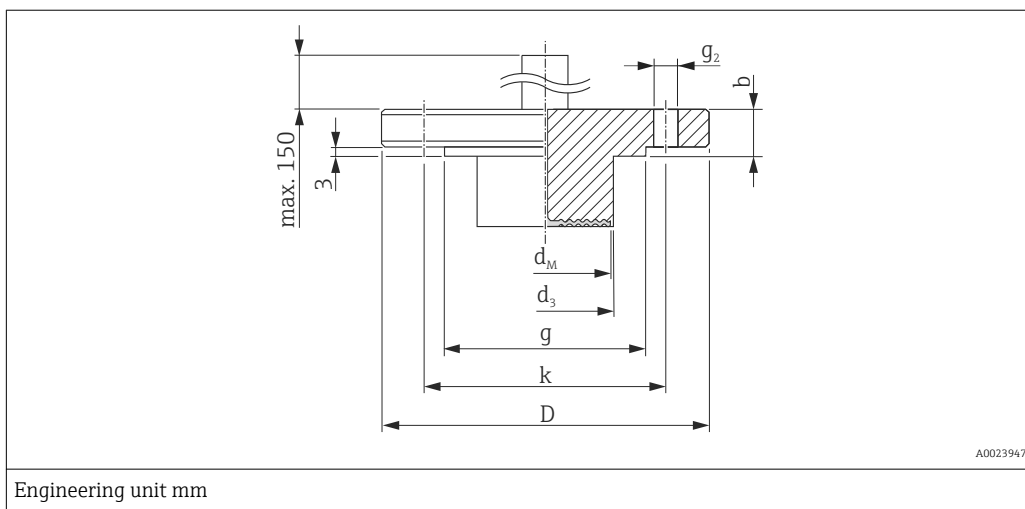

Flange <sup>1) 2)</sup>							Boltholes			Diaphragm seal		Option <sup>3)</sup>	
Nominal diameter	Nominal pressure	Shape <sup>4)</sup>	D	Thickness	Raised face	Barrel (extended diaphragm seal) length	Barrel (extended diaphragm seal) diameter	Number	g <sub>2</sub>	Hole circle	Max. diameter process isolating diaphragm		Weight
					b	g	L			d <sub>3</sub>	k		
			[mm]	[mm]	[mm]	[mm]	[mm]			[mm]	[mm]		
DN 80	PN 10-40	B1 (D)	200	24	-	50	76	8	18	160	72	6.2 (13.67)	C
						100						6.7 (14.77)	
						200						7.8 (17.20)	

- 1) Material: AISI 316L
- 2) For process isolating diaphragms made of Alloy C276, Monel oder tantalum, the raised face of the flange and the barrel pipe are made of 316L.
- 3) Product Configurator, order code for "Process connection"
- 4) Name as per DIN 2527 provided in brackets

Process connections FMD77 with diaphragm seal, high-pressure side

ASME flanges, connection dimensions in accordance with B 16.5, raised face RF

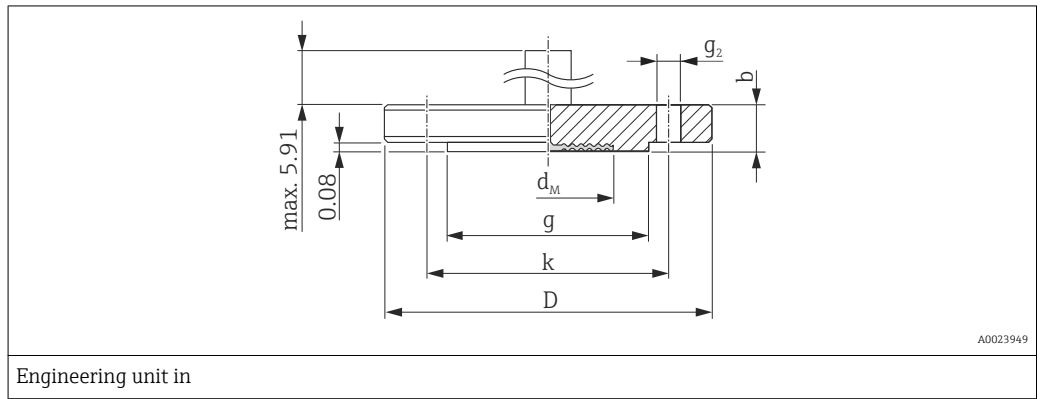

Flange <sup>1) 2) 3)</sup>					Boltholes			Diaphragm seal	Weight	Approval <sup>4)</sup>	Option <sup>5)</sup>
Nominal diameter	Class	D	Thickness	Raised face	Number	g <sub>2</sub>	Hole circle	Max. diameter of the process isolating diaphragm			
			b	g			k	d <sub>M</sub>			
[in]	[lb./sq.in]	[in]	[in]	[in]		[in]	[in]	[in]	[kg (lb)]		
2	150	6	0.75	3.62	4	0.75	4.75	2.32	2.6 (5.73)	CRN	N
2	300	6.5	0.88	3.62	8	0.75	5	2.32	3.4 (7.5)	CRN	O
3	150	7.5	0.94	5	4	0.75	6	3.5	5.1 (11.25)	CRN	P
3	300	8.25	1.12	5	8	0.75	6	3.5	7.0 (15.44)	CRN	R
4	150	9	0.94	6.19	8	0.75	7.5	3.5	7.2 (15.88)	CRN	T
4	300	10	1.25	6.19	8	0.88	7.88	3.5	11.7 (25.8)	CRN	W
<b>Compact version</b>											
3	150	7.5	0.94	5	4	0.75	6	3.5	5.1 (11.25)	-	5
3	300	8.25	1.12	5	8	0.75	6	3.5	7 (15.44)	-	6
4	150	9	0.94	6.19	8	0.75	7.5	3.5	7.2 (15.88)	-	8

- 1) Material: AISI 316/316L. Combination of AISI 316 for required pressure resistance and AISI 316L for required chemical resistance (dual rated)
- 2) The surface roughness of the wetted surfaces, including the raised face of flanges (all standards) made of Alloy C276, Monel, tantalum, rhodium-gold or PTFE, is  $R_a < 0.8 \mu\text{m}$  (31.5  $\mu\text{in}$ ). Lower surface roughness on request.
- 3) The flange raised face is made of the same material as the process isolating diaphragm.
- 4) CSA approval: Product Configurator, order code for "Approval"
- 5) Product Configurator, order code for "Process connection"

ASME flanges with barrel (extended diaphragm seal), connection dimensions in accordance with ASME B 16.5, raised face RF

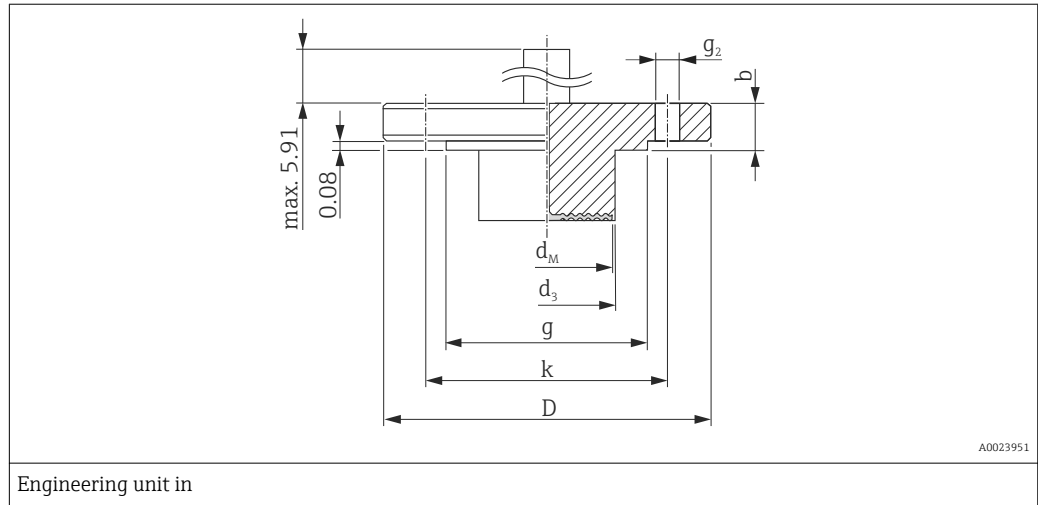

Flange <sup>1) 2)</sup>							Boltholes			Diaphragm seal	Weight	Option <sup>3)</sup>
Nominal diameter	Class	D	Thickness	Raised face	Barrel (extended diaphragm seal) length	Barrel (extended diaphragm seal) diameter	Number	g <sub>2</sub>	Hole circle	Max. diameter process isolating diaphragm		
[in]	[lb./sq.in]	[in]	[in]	[in]	[in]	[in]		[in]	[in]		d <sub>M</sub>	[kg (lb)]
3	150	7.5	0.94	5	2	2.99	4	0.75	6	2.83	6 (13.23)	Q
					4						6.6 (14.55)	
					6						7.1 (15.66)	
					8						7.7 (16.98)	
<b>Compact version</b>												
3	150	7.5	0.94	5	2	2.99	4	0.75	6	2.83	6 (13.23)	7
					4						6.6 (14.55)	
					6						7.1 (15.66)	
					8						7.7 (16.98)	

1) Material: AISI 316/316L

2) For process isolating diaphragms made of Alloy C276, Monel or tantalum, the raised face of the flange and the barrel pipe are made of 316L.

3) Product Configurator, order code for "Process connection"

**Process connections FMD77 with diaphragm seal, high-pressure side**

**JIS flanges, connection dimensions in accordance with JIS B 2220 BL, raised face RF**

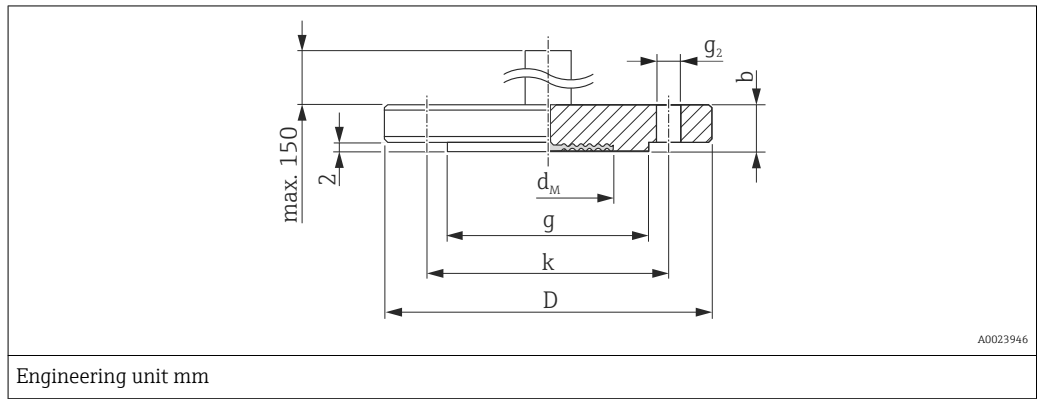

Flange <sup>1) 2) 3)</sup>					Boltholes			Diaphragm seal	Weight	Option <sup>4)</sup>
Nominal diameter	Nominal pressure	D	Thickness	Raised face	Number	g <sub>2</sub>	Hole circle	Max. diameter of the process isolating diaphragm		
			b	g			k	d <sub>M</sub>		
		[mm]	[mm]	[mm]			[mm]	[mm]	[kg (lb)]	
50 A	10 K	155	16	96	4	19	120	59	2.3 (5.07)	X
80 A	10 K	185	18	126	8	19	150	89	3.5 (7.72)	1
100 A	10 K	210	18	151	8	19	175	89	4.7 (10.36)	4

- 1) Material: AISI 316
- 2) The surface roughness of the wetted surfaces, including the raised face of flanges (all standards) made of Alloy C276, Monel, tantalum, rhodium-gold or PTFE, is  $R_a < 0.8 \mu\text{m}$  (31.5  $\mu\text{in}$ ). Lower surface roughness on request.
- 3) The flange raised face is made of the same material as the process isolating diaphragm.
- 4) Product Configurator, order code for "Process connection"

**Process connections FMD77 with diaphragm seal, low-pressure side**

Process connection low-pressure side	Material	Seal	Option <sup>1)</sup>
Mounting: 7/16 – 20 UNF, Process isolating diaphragm low-pressure side AISI 316L			
1/4 – 18 NPT IEC 61518	C22.8	FKM Viton	B
1/4 – 18 NPT IEC 61518,	AISI 316L	FKM Viton	D
1/4 – 18 NPT IEC 61518	Alloy C276	FKM Viton	F
1/4 – 18 NPT IEC 61518	AISI 316L	PTFE+C4-ring	H
1/4 – 18 NPT IEC 61518	Alloy C276	PTFE+C4-ring	J
1/4 – 18 NPT IEC 61518	AISI 316L	EPDM	K
1/4 – 18 NPT IEC 61518	Alloy C276	EPDM	L
1/4 – 18 NPT IEC 61518	AISI 316L	Kalrez	M
1/4 – 18 NPT IEC 61518	Alloy C276	Kalrez	N
1/4 – 18 NPT IEC 61518	AISI 316L	Chemraz	P
1/4 – 18 NPT IEC 61518	Alloy C276	Chemraz	Q
1/4 – 18 NPT IEC 61518	AISI 316L	FKM Viton, cleaned from oil and grease	S
1/4 – 18 NPT IEC 61518	AISI 316L	FKM Viton, cleaned for oxygen service	T
RC 1/4	AISI 316L	FKM Viton	U

- 1) Product Configurator, order code for "Process connection"

FMD78 basic device

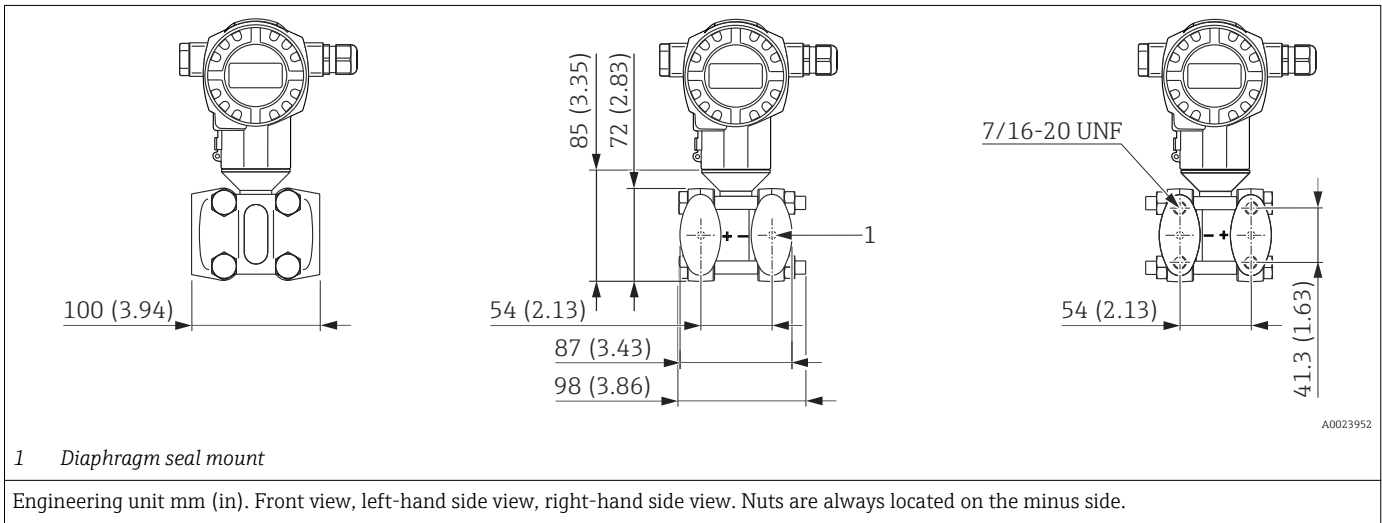

**Process connections FMD78 with diaphragm seal**



- The following drawings are drawings that illustrate how the system works in principle. In other words, the dimensions of a diaphragm seal supplied can deviate from the dimensions given in this document.
- With the use of high-temperature oils the design can deviate strongly.
- Observe the "Planning instructions, diaphragm seal systems" section → 81
- For further information please contact your local Endress+Hauser Sales Center.

**Diaphragm seal cell structure**

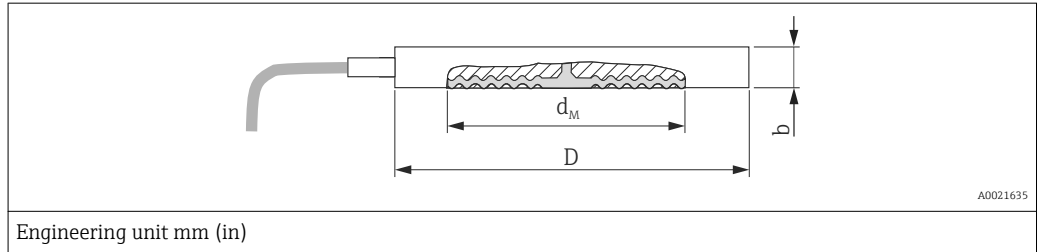

Flange				Diaphragm seal			Approval <sup>1)</sup>	Option <sup>2)</sup>
Material	Nominal diameter	Nominal pressure <sup>3)</sup>	D	Thickness b	Max. diameter of the process isolating diaphragm d <sub>M</sub>	Weight of two diaphragm seals <sub>2</sub> [kg (lb)]		
			[mm]	[mm]	[mm]			
AISI 316L	DN 50	PN 16-400	102	20	59	2.6 (5.73)	-	UF
	DN 80	PN 16-400	138	20	89	4.6 (10.14)	-	UH
	DN 100	PN 16-400	162	20	89	6.2 (13.67)	-	UJ
	[in]	[lb/sq.in]	[in (mm)]	[in (mm)]	[in (mm)]			
	2	150-2500	4.01 (102)	0.79 (20)	2.32 (59)	2.6 (5.73)	CRN	VF
	3	150-2500	5.35 (136)	0.79 (20)	3.50 (89)	4.6 (10.14)	CRN	VH
	4	150-2500	6.22 (158)	0.79 (20)	3.50 (89)	6.2 (13.67)	CRN	VJ

- 1) CSA approval: Product Configurator, order code for "Approval"
- 2) Product Configurator, order code for "Process connection"
- 3) The specified nominal pressure applies to the diaphragm seal. The maximum pressure for the measuring device is dependent on the lowest-rated element, with regard to pressure, of the selected components → 41.

Process connections FMD78 with diaphragm seal

Thread ISO 228 G 1/2 B and ANSI 1/2 MNPT, separator with PTFE seal

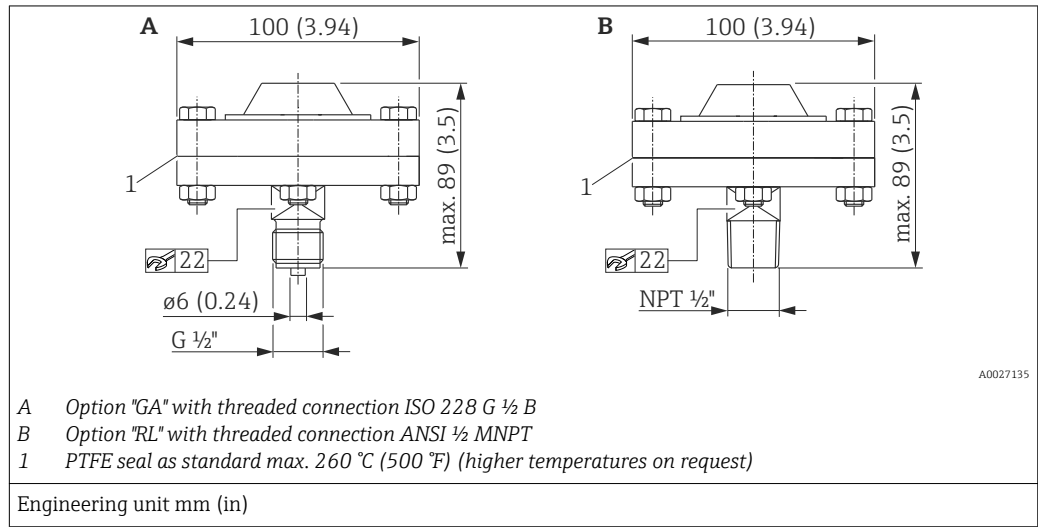

Material	Description	Measuring range	Nominal pressure	Weight	Option <sup>1)</sup>
		[bar (psi)]		[kg (lb)]	
AISI 316L (1.4404), screws made of A2	ISO 228 G 1/2 B EN837	≤ 40 (580)	PN 40	1.43 (3.15)	GA
	ANSI 1/2 MNPT				RL

1) Product Configurator, order code for "Process connection"

DRD DN50 (65 mm)

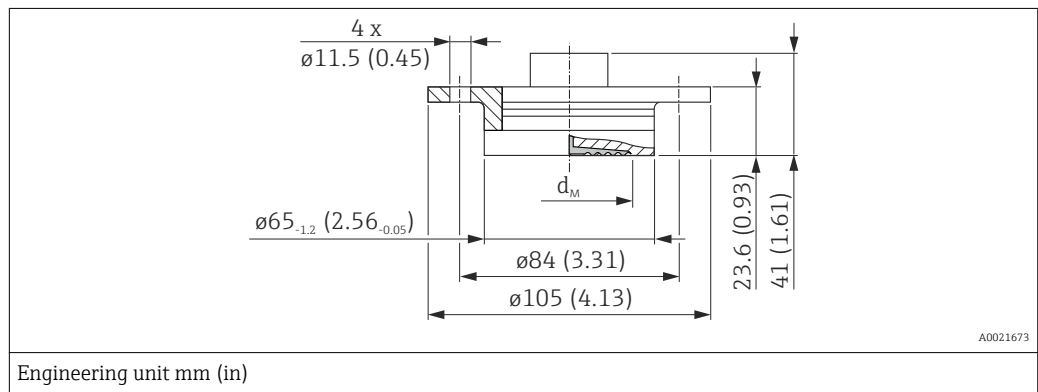

Material <sup>1)</sup>	Nominal pressure	Max. diameter of the process isolating diaphragm		Weight	Option <sup>2)</sup>
		Standard	With TempC diaphragm		
		d <sub>M</sub>	d <sub>M</sub>		
		[mm]	[mm]	[kg (lb)]	
AISI 316L	PN 25	50	48	0.75 (1.65)	TK <sup>3)</sup>

- 1) Surface roughness of the wetted surfaces R<sub>a</sub> < 0.76 µm (29.9 µin) as standard.
- 2) Product Configurator, order code for "Process connection"
- 3) Alternatively available with TempC diaphragm.

Tri-Clamp ISO 2852

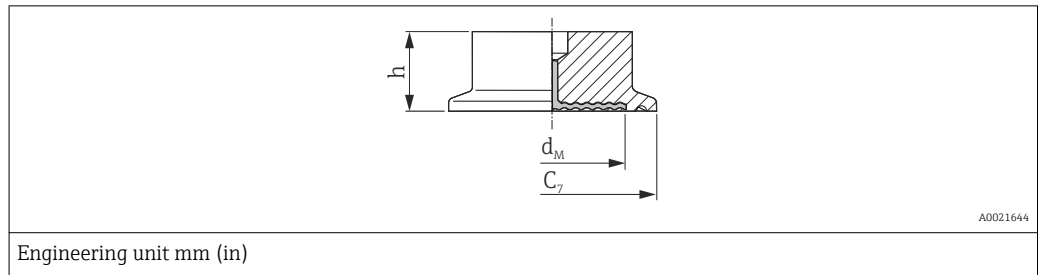

Material <sup>1)</sup>	Nominal diameter ISO 2852	Nominal diameter DIN 32676	Nominal diameter	Diameter	Max. diameter of the process isolating diaphragm		Height	Weight	Approval <sup>2)</sup>	Option <sup>3)</sup>
					Standard	With TempC diaphragm				
					C <sub>7</sub>	d <sub>M</sub>				
			[in]	[mm]	[mm]	[mm]	[mm]	[kg (lb)]		
AISI 316L	ND 25 / 33.7	DN 25	1	50.5	24	-	37	0.32 (0.71)	EHEDG, 3A	TB
	ND 38	DN 40	1 ½	50.5	36	36	30	1 (2.21)	EHEDG, 3A	TC <sup>4) 5)</sup>
	ND 51 / 40	DN 50	2	64	48	41	30	1.1 (2.43)	EHEDG, 3A	TD <sup>4) 5)</sup>
	ND 63.5	DN 50	2 ½	77.5	61	61	30	0.7 (1.54)	EHEDG, 3A	TE <sup>6)</sup>
	ND 76.1	-	3	91	73	61	30	1.2 (2.65)	EHEDG, 3A	TF <sup>5)</sup>

- 1) Surface roughness of the wetted surfaces  $R_a < 0.76 \mu\text{m}$  (29.9  $\mu\text{in}$ ) as standard. Lower surface roughness on request.
- 2) CSA approval: Product Configurator, order code for "Approval".
- 3) Product Configurator, order code for "Process connection"
- 4) Diaphragm seal version optionally in conformity with ASME BPE for use in biochemical processes, wetted surfaces  $R_a < 0.38 \mu\text{m}$  (15  $\mu\text{in}$ ), electropolished; to be ordered using feature "Additional options 1" or "Additional options 2", version "O" in the order code.
- 5) Alternatively available with TempC diaphragm.
- 6) With TempC diaphragm

Process connections FMD78 with diaphragm seal

SMS nozzles with coupling nut

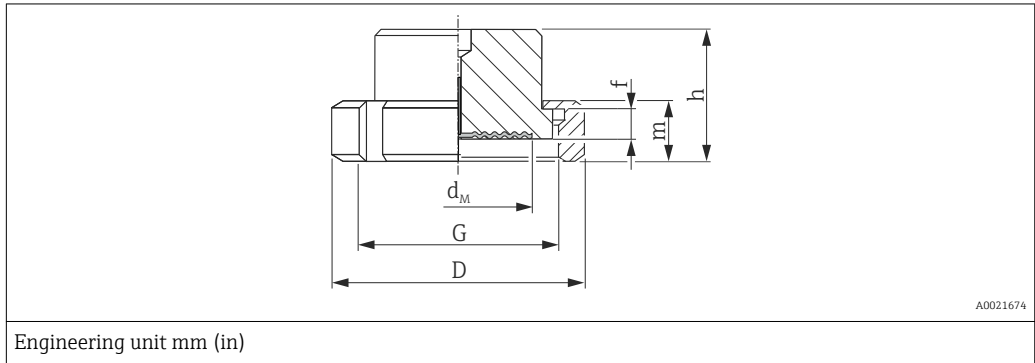

Material <sup>1)</sup>	Nominal diameter	Nominal pressure	D	Nozzle height	Thread	Height	Height	Max. diameter of the diaphragm	Weight	Approval	Option <sup>2)</sup>		
				f		G	m					h	d <sub>M</sub>
				[mm]		[mm]	[mm]					[mm]	[mm]
AISI 316L	1 ½	PN 25	74	4	Rd 60 - 1/6	25	57	36	0.65 (1.43)	3A, EHEDG	TH <sup>3)</sup>		
	2	PN 25	84	4	Rd 70 - 1/6	26	62	48	1.05 (2.32)	3A, EHEDG	TI <sup>3)</sup>		

- 1) Surface roughness of the wetted surfaces  $R_a < 0.76 \mu\text{m}$  (29.9  $\mu\text{in}$ ) as standard.
- 2) Product Configurator, order code for "Process connection"
- 3) With TempC diaphragm

Hygienic connection, sanitary tank spud, extended diaphragm seal 2"

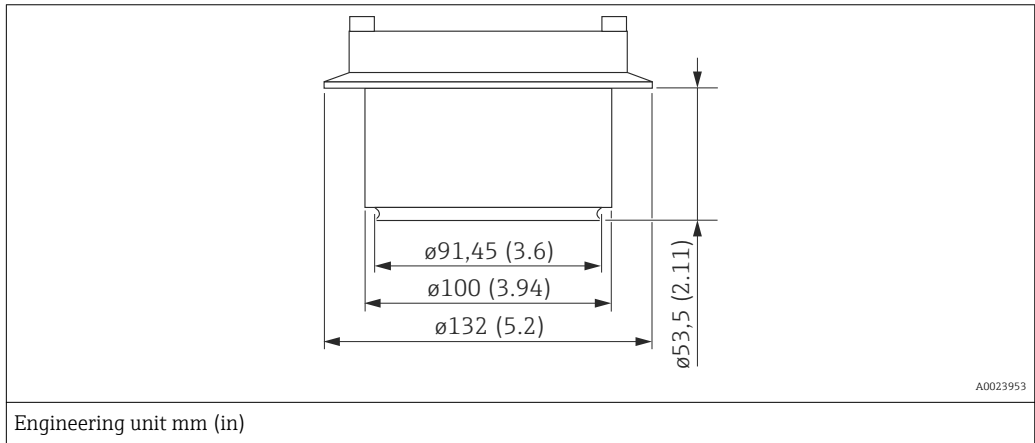

Material <sup>1)</sup>	Weight kg (lbs)	Approval <sup>2)</sup>	Option
AISI 316L	2.5 (5.51)	3A, CRN	WH

- 1) Surface roughness of the wetted surfaces  $R_a < 0.8 \mu\text{m}$  (31.5  $\mu\text{in}$ ) as standard. Lower surface roughness on request.
- 2) CSA approval: Product Configurator, order code for "Approval"

Taper adapter with coupling nut, DIN 11851

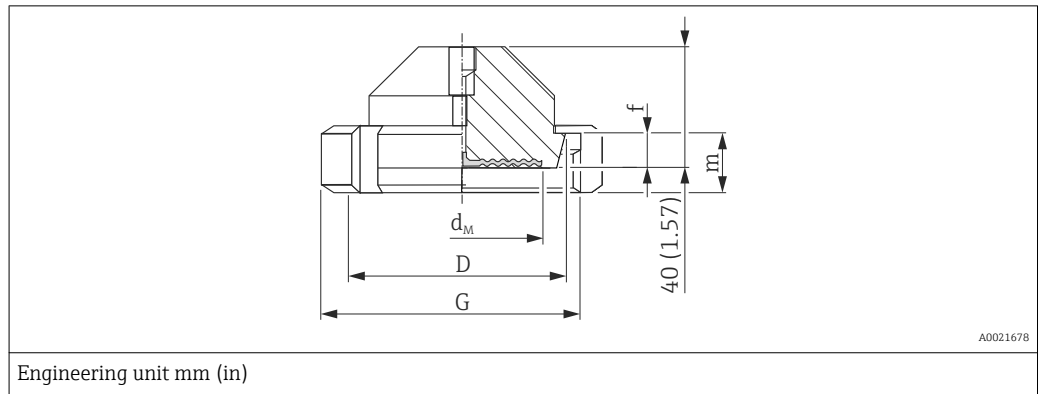

Material <sup>1)</sup>	Taper adapter				Slotted nut		Diaphragm seal			Approval	Option <sup>2)</sup>
							Max. diameter of the process isolating diaphragm		Weight		
	Nominal diameter	Nominal pressure	D	Nozzle height	Thread	Height	Standard	With TempC diaphragm			
		PN		f				G	m		
	[bar]	[mm]	[mm]		[mm]	[mm]	[mm]				
AISI 316L	DN 40	PN 40	56	10	Rd 65 x 1/6"	21	38	36	0.45 (0.99)	3A, EHEDG	MZ <sup>3)</sup>
	DN 50	PN 25	68.5	11	Rd 78 x 1/6"	19	52	48	1.1 (2.43)	3A, EHEDG	MR <sup>4)</sup>
	DN 65	PN 25	86	12	Rd 95 x 1/6"	21	66	61	2.0 (4.41)	3A, EHEDG	MS <sup>4)</sup>
	DN 80	PN 25	100	12	Rd 110 x 1/4"	26	81	61	2.55 (5.62)	3A, EHEDG	MT <sup>4)</sup>

- 1) Surface roughness of the wetted surfaces  $R_a < 0.76 \mu\text{m}$  (29.9  $\mu\text{in}$ ) as standard.
- 2) Product Configurator, order code for "Process connection"
- 3) With TempC diaphragm
- 4) Alternatively available with TempC diaphragm.

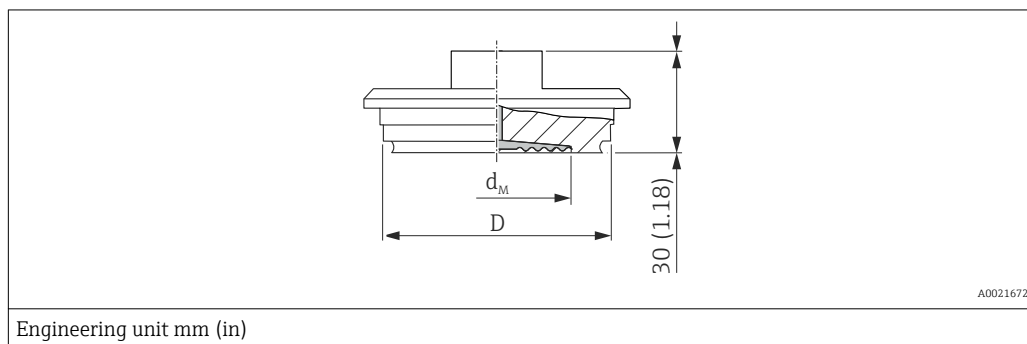
**Process connections FMD78  
with diaphragm seal**
**Varivent for pipes**

Material <sup>1)</sup>	Description	Nominal pressure	D	Max. diameter of the process isolating diaphragm		Weight [kg (lb)]	Approval	Option <sup>2)</sup>
				Standard	With TempC diaphragm			
				d <sub>M</sub>	d <sub>M</sub>			
				[mm]	[mm]			
AISI 316L	Type F for pipes DN 25 - DN 32	PN 40	50	34	36	0.4 (0.88)	EHEDG, 3A	TU <sup>3)</sup>
AISI 316L	Type N for pipes DN 40 - DN 162	PN 40	68	58	61	0.8 (1.76)	EHEDG, 3A	TR <sup>4)</sup>

1) Surface roughness of the wetted surfaces  $R_a < 0.76 \mu\text{m}$  ( $29.9 \mu\text{in}$ ) as standard.

2) Product Configurator, order code for "Process connection"

3) With TempC diaphragm

4) Alternatively available with TempC diaphragm.

**Process connections FMD78 with diaphragm seal**

**NEUMO BioControl**

Process temperature range: -10 to +200 °C (+14 to +392 °F)

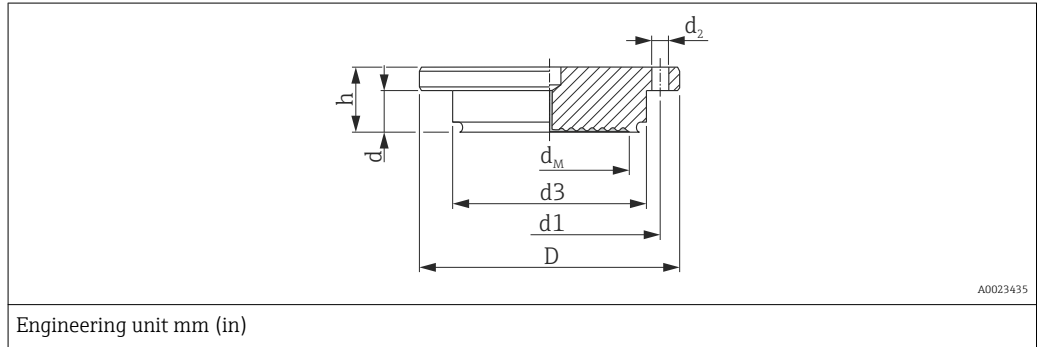

Material <sup>1)</sup>	NEUMO BioControl							Diaphragm seal			Approval	Option <sup>2)</sup>
								Max. diameter of the process isolating diaphragm		Weight		
	Nominal of the diaphragm	Nominal pressure	Diameter			Hole circle	Height	Standard	With TempC diaphragm			
		PN	D	d <sub>2</sub>	d <sub>3</sub>	d <sub>1</sub>	m	d <sub>M</sub>	d <sub>M</sub>	[kg (lb)]		
AISI 316L	DN 50	PN 16	90	4 x Ø 9	50	70	27	40	36	1.1 (2.43)	3A	S4 <sup>3)</sup>
	DN 80	PN 16	140	4 x Ø 11	87.4	115	37	61	61	2.6 (5.73)	3A	S6 <sup>3)</sup>

- 1) Surface roughness of the wetted surfaces  $R_a < 0.76 \mu\text{m}$  (29.9  $\mu\text{in}$ ) as standard.
- 2) Product Configurator, order code for "Process connection"
- 3) With TempC diaphragm

**Universal process adapter**

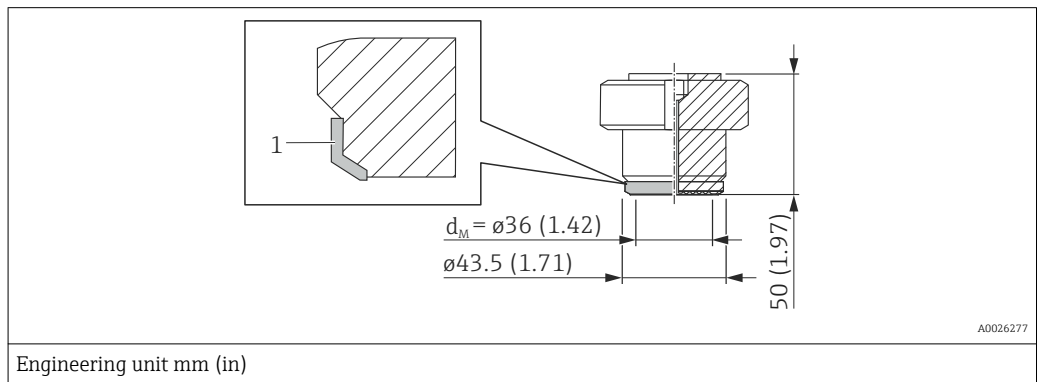

Description	Material <sup>1)</sup>	Weight	Approval	Option <sup>2)</sup>
		[kg (lb)]		
Universal process adapter incl. silicone molded seal (1) (Spare part no.: 52023572) FDA 21CFR177.2600/USP Class VI-70C	AISI 316L (1.4435)	0.8 (1.76)	3A, EHEDG	00 <sup>3) 4)</sup>

- 1) Surface roughness of the wetted surfaces  $R_a < 0.76 \mu\text{m}$  (29.9  $\mu\text{in}$ ) as standard.
- 2) Product Configurator, order code for "Process connection"
- 3) Endress+Hauser supplies these slotted nuts in stainless steel AISI 304 (DIN/EN material number 1.4301) or in AISI 304L (DIN/EN material number 1.4307).
- 4) With TempC diaphragm.

Process connections FMD78  
with diaphragm seal

EN/DIN flanges, connection dimensions in accordance with EN 1092-1/DIN 2527,  
JIS flanges, connection dimensions in accordance with JIS B 2220 BL

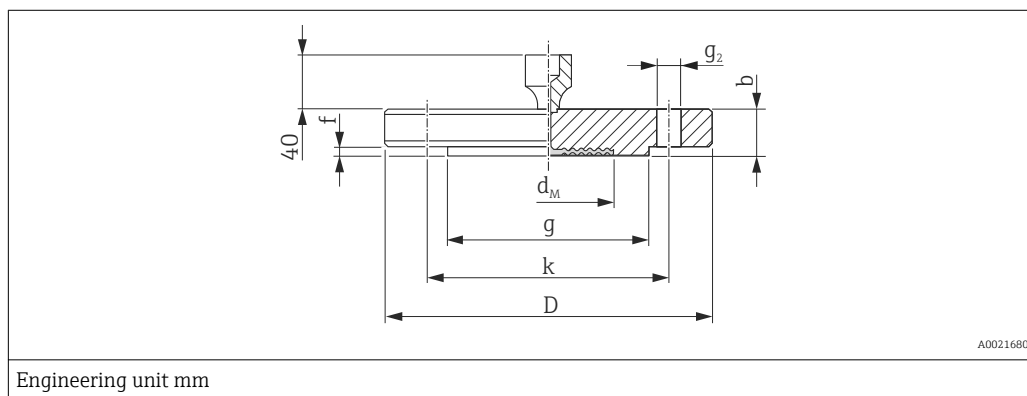

Flange <sup>1) 2) 3)</sup>							Boltholes			Diaphragm seal		Option <sup>4)</sup>
Nominal diameter	Nominal pressure	Shape <sup>5)</sup>	D	Thickness			Number	g <sub>2</sub>	Hole circle	Max. diameter process isolating diaphragm	Weight	
				b	g	f						
				[mm]	[mm]	[mm]			[mm]			
DN 50	PN 10-40	B1 (D)	165	20	102	3	4	18	125	59	3.0 (6.62)	B3
DN 80	PN 10-40	B1 (D)	200	24	138	3.5	8	18	160	89	5.3 (11.69)	B5
DN 100	PN 10-16	B1 (C)	220	20	-	4	8	18	180	89	4.5 (9.92)	BT
DN 100	PN 25-40	B1 (D)	235	24	162	5	8	22	190	89	7 (15.44)	B6

- 1) Material: AISI 316L
- 2) The surface roughness of the wetted surfaces, including the raised face of flanges (all standards) made of Alloy C276, Monel, tantalum, rhodium-gold or PTFE is  $R_a < 0.8 \mu\text{m}$  ( $31.5 \mu\text{in}$ ). Lower surface roughness on request.
- 3) The flange raised face is made of the same material as the process isolating diaphragm.
- 4) Product Configurator, order code for "Process connection"
- 5) Name as per DIN 2527 provided in brackets

Flange <sup>1) 2) 3)</sup>						Boltholes			Diaphragm seal		Option <sup>4)</sup>
Nominal diameter	Nominal pressure	D	Thickness			Number	g <sub>2</sub>	Hole circle	Max. diameter process isolating diaphragm	Weight	
			b	g	f						
			[mm]	[mm]	[mm]			[mm]			
50 A	10 K	155	16	96	2	4	19	120	59	2.3 (5.07)	KF
80 A	10 K	185	18	127	2	8	19	150	89	3.3 (7.28)	KL
100 A	10 K	210	18	151	2	8	19	175	89	4.4 (9.7)	KH

- 1) Material: AISI 316L
- 2) The surface roughness of the wetted surfaces, including the raised face of flanges (all standards) made of Alloy C276, Monel, tantalum, rhodium-gold or PTFE is  $R_a < 0.8 \mu\text{m}$  ( $31.5 \mu\text{in}$ ). Lower surface roughness on request.
- 3) The flange raised face is made of the same material as the process isolating diaphragm.
- 4) Product Configurator, order code for "Process connection"

Process connections FMD78 with diaphragm seal

EN/DIN flanges with barrel (extended diaphragm seal), connection dimensions in accordance with EN 1092-1/DIN 2527 and DIN 2501-1

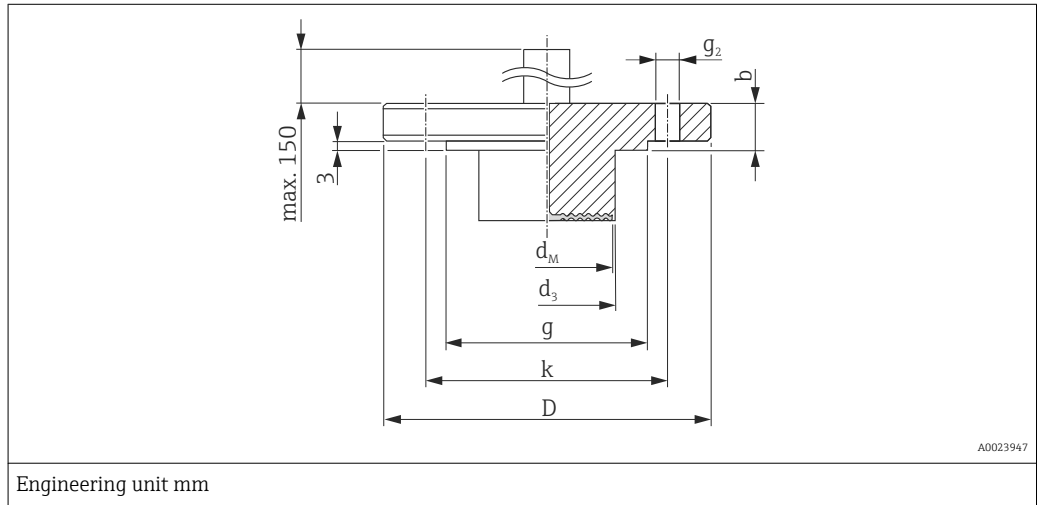

Flange <sup>1) 2)</sup>								Boltholes			Diaphragm seal		Option <sup>3)</sup>
Nominal diameter	Nominal pressure	Shape <sup>4)</sup>	D	Thickness	Raised face	Barrel (extended diaphragm seal) length	Barrel (extended diaphragm seal) diameter	Number	g <sub>2</sub>	Hole circle	Max. diameter process isolating diaphragm	Weight	
					b	g	L			d <sub>3</sub>			
			[mm]	[mm]	[mm]	[mm]	[mm]			[mm]			
DN 80	PN 10-40	B1 (D)	200	24	138	50	76	8	18	160	72	6.2 (13.67)	D4
						100						6.7 (14.77)	
						200						7.8 (17.20)	

- 1) Material: AISI 316L
- 2) For process isolating diaphragms made of Alloy C276, Monel oder tantalum, the raised face of the flange and the barrel pipe are made of 316L.
- 3) Product Configurator, order code for "Process connection"
- 4) Name as per DIN 2527 provided in brackets

Process connections FMD78 with diaphragm seal

ASME flanges, in accordance with connection dimensions ASME B 16.5, raised face RF

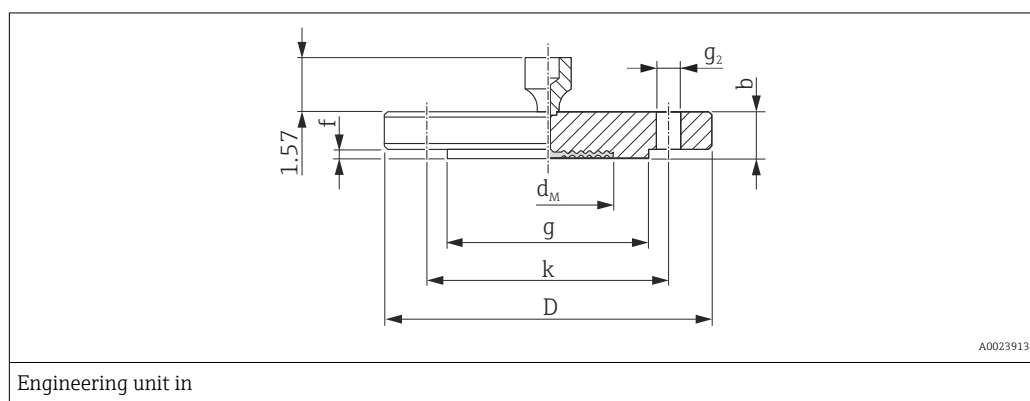

Flange <sup>1) 2) 3)</sup>						Boltholes			Diaphragm seal		Approval <sup>4)</sup>	Option <sup>5)</sup>
Nominal diameter	Class	D	Thickness			Number	g <sub>2</sub>	Hole circle	Max. diameter of the process isolating diaphragm	Weight		
			b	g	f			k				
[in]	[lb./sq.in]	[in]	[in]	[in]	[in]		[in]	[in]	[in]	[kg (lb)]		
2	150	6	0.75	3.62	0.06	4	0.75	4.75	2.32	2.2 (4.85)	CRN	AF
2	300	6.5	0.88	3.62	0.06	8	0.75	5	2.32	3.4 (7.5)	CRN	AR
3	150	7.5	0.94	5	0.06	4	0.75	6	3.5	5.1 (11.25)	CRN	AG
3	300	8.25	1.12	5	0.06	8	0.75	6	3.5	7.0 (15.44)	CRN	AS
4	150	9	0.94	6.19	0.06	8	0.75	7.5	3.5	7.2 (15.88)	CRN	AH
4	300	10	1.25	6.19	0.06	8	0.88	7.88	3.5	11.7 (25.8)	CRN	AT

- 1) Material AISI 316/316L: Combination of AISI 316 for required pressure resistance and AISI 316L for required chemical resistance (dual rated)
- 2) The surface roughness of the wetted surfaces, including the raised face of flanges (all standards) made of Alloy C276, Monel, tantalum, rhodium-gold or PTFE, is  $R_a < 0.8 \mu\text{m}$  (31.5  $\mu\text{in}$ ). Lower surface roughness on request.
- 3) The flange raised face is made of the same material as the process isolating diaphragm.
- 4) CSA approval: Product Configurator, order code for "Approval"
- 5) Product Configurator, order code for "Process connection"

ASME flanges with barrel (extended diaphragm seal), connection dimensions in accordance with ASME B 16.5, raised face RF

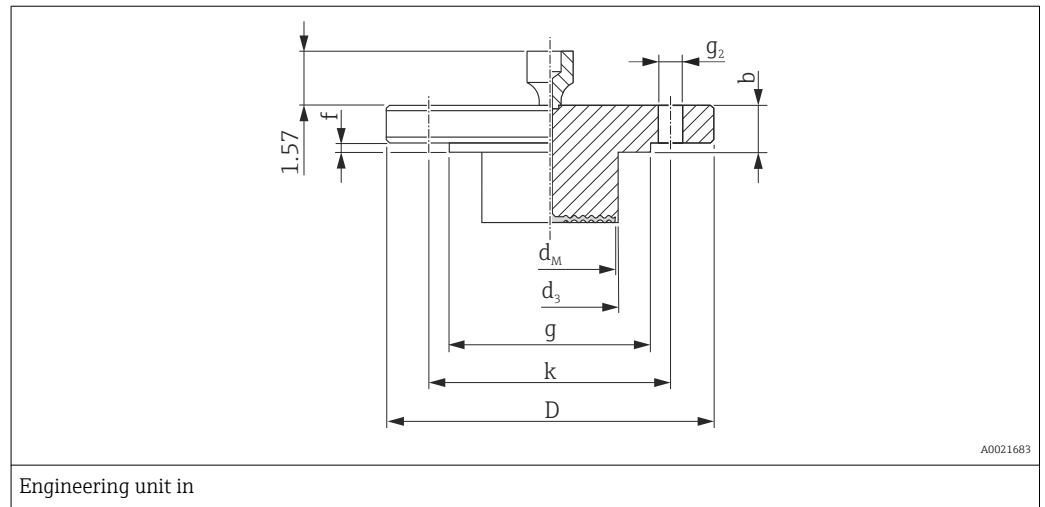

Flange <sup>1) 2)</sup>						Boltholes			Diaphragm seal		Approval <sup>3)</sup>	Option <sup>4)</sup>
Nominal diameter	Class	D	Thickness	Raised face		Number	g <sub>2</sub>	Hole circle	Max. diameter of the process isolating diaphragm	Weight		
				b	g							
[in]	[lb./sq.in]	[in]	[in]	[in]	[in]		[in]	[in]	[in]	[kg (lb)]		
3	150	7.5	0.94	5	0.06	4	0.75	6	2.83	<sup>5)</sup>	CRN	J4 <sup>5)</sup>
4	150	9	0.94	6.19	0.06	8	0.75	7.5	3.5	<sup>5)</sup>	CRN	J5 <sup>5)</sup>

- 1) Material: AISI 316/316L. Combination of AISI 316 for required pressure resistance and AISI 316L for required chemical resistance (dual rated)
- 2) For process isolating diaphragms made of Alloy C276, Monel or tantalum, the flange raised face and the barrel pipe are made of 316L.
- 3) CSA approval: Product Configurator, order code for "Approval"
- 4) Product Configurator, order code for "Process connection"
- 5) Available with 2", 4", 6" or 8" barrel (extended diaphragm seal), for barrel diameter and weight see the following table

Option <sup>1)</sup>	Nominal diaphragm	Class	Barrel (extended diaphragm seal) length	Barrel (extended diaphragm seal) process isolating diaphragm	Weight
			(L)	d <sub>3</sub>	
	[in]	[lb./sq.in]	in (mm)	in (mm)	[kg (lb)]
J4	3	150	2 (50.8) / 4 (101.6) / 6 (152.4) / 8 (203.2)	2.99 (76)	6.0 (13.2) / 6.6 (14.5) / 7.1 (15.7) / 7.8 (17.2)
J5	4	150	2 (50.8) / 4 (101.6) / 6 (152.4) / 8 (203.2)	3.7 (94)	8.6 (19) / 9.9 (21.8) / 11.2 (24.7) / 12.4 (27.3)

- 1) Product Configurator, order code for "Process connection"

Separate housing: Wall and pipe mounting with mounting bracket

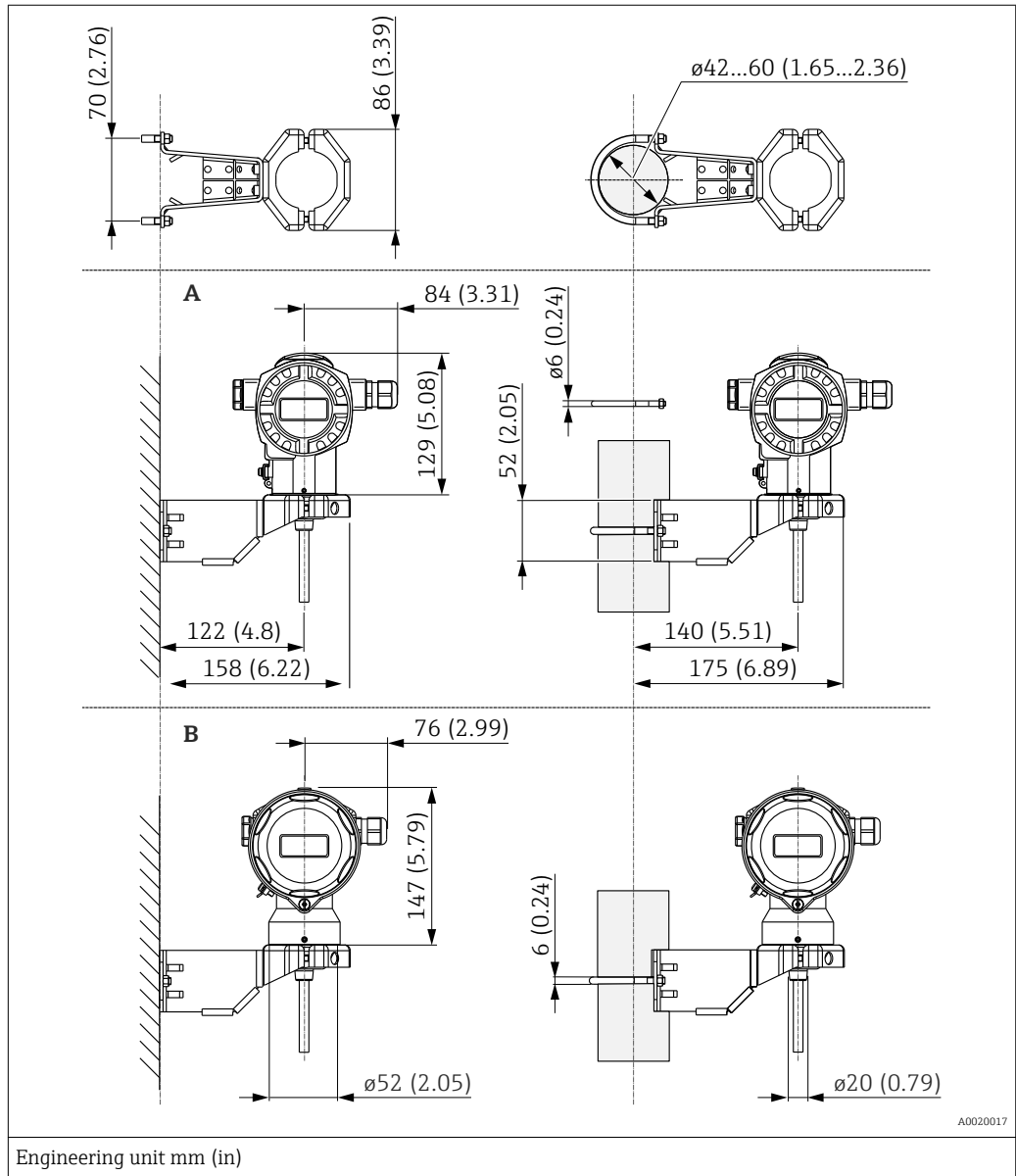

Position	Description	Weight in kg (lb)		Option <sup>1)</sup>
		Housing (T14 or T17)	Mounting bracket	
A	Dimensions with T14 housing, optional side display	→ 43	0.5 (1.10)	U
B	Dimensions with T17 housing, optional side display			

1) Product Configurator, order code for "Additional options 2", version "G"

Also available for order as a separate accessory: Part number 71102216

**Materials not in contact with process Transmitter housing**

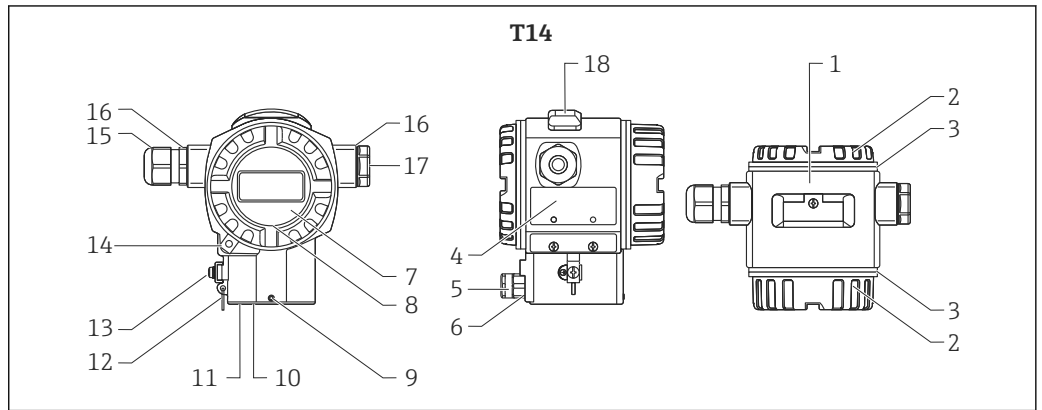

A0020019

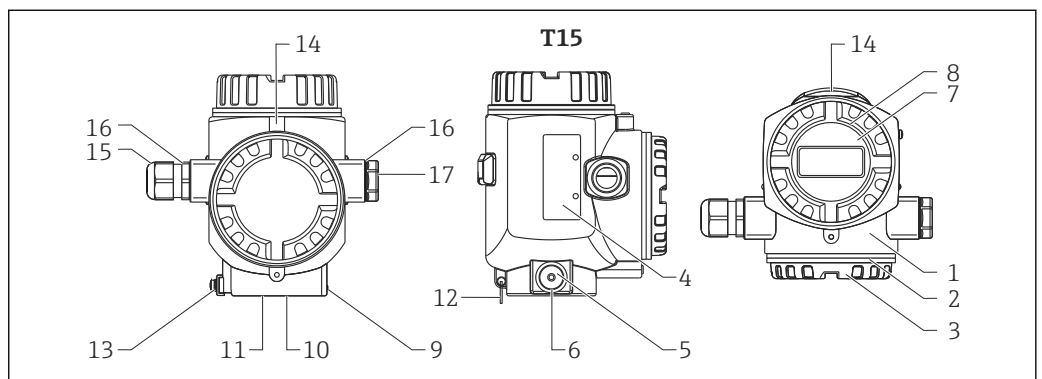

A0020020

Item number	Component part	Material
1	T14 and T15 housing, RAL 5012 (blue)	<ul style="list-style-type: none"> <li>■ Die-cast aluminum with protective powder-coating on polyester base</li> <li>■ Thread coating: Heat-curing lubricant varnish</li> </ul>
2	Cover, RAL 7035 (gray)	Die-cast aluminum with protective powder-coating on polyester base
3	Cover seal	EPDM
4	Nameplates	AISI 316L (1.4404)
5	Pressure compensation filter	AISI 316L (1.4404) and PBT-FR
6	Pressure compensation filter, O-ring	VMQ or EPDM
7	Sight glass	Mineral glass
8	Sight glass seal	Silicone (VMQ)
9	Screw	A4
10	Sealing ring	EPDM
11	Snap ring	PA66-GF25
12	Snap ring for nameplates	AISI 304 (1.4301)/AISI 316 (1.4401)
13	External ground terminal	AISI 304 (1.4301)
14	Cover clamp	Clamp AISI 316L (1.4435), screw A4
15	Cable entry	Polyamide (PA) or CuZn nickel-plated
16	Seal of cable entry and plug	Silicone (VMQ)

Item number	Component part	Material
17	Blind plug	PBT-GF30 FR, for dust ignition-proof: AISI 316L (1.4435)
18	External operation (keys and key cover), RAL 7035 (gray)	Polycarbonate PC-FR, screw A4

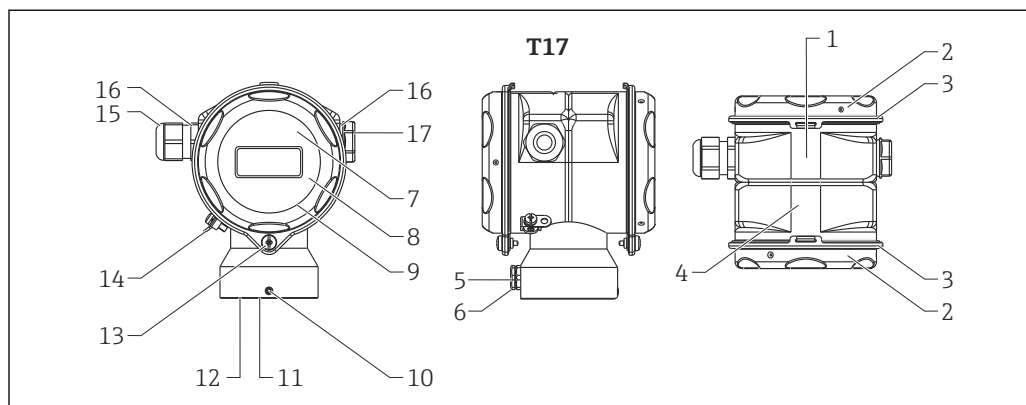

A0020021

Item number	Component part	Material
1	T17 housing	AISI 316L (1.4404)
2	Cover	
3	Cover seal	EPDM
4	Nameplates	Lasered on
5	Pressure compensation filter	AISI 316L (1.4404) and PBT-FR
6	Pressure compensation filter, O-ring	VMQ or EPDM
7	Sight glass for non-hazardous area, ATEX Ex ia, NEPSI Zone 0/1 Ex ia, IECEx Zone 0/1 Ex ia, FM NI, FM IS, CSA IS	Polycarbonate (PC)
8	Sight glass for ATEX 1/2 D, ATEX 1/3 D, ATEX 1 GD, ATEX 1/2 GD, ATEX 3 G, FM DIP, CSA dust ignition-proof	Mineral glass
9	Sight glass seal	EPDM
10	Screw	A2-70
11	Sealing ring	EPDM
12	Snap ring	PA6
13	Screw	A4-50 Thread coating: Heat-curing lubricant varnish
14	External ground terminal	AISI 304 (1.4301)
15	Cable entry	Polyamide PA, for dust ignition-proof: CuZn nickel-plated
16	Seal of cable entry and plug	Silicone (VMQ)
17	Blind plug	PBT-GF30 FR, for dust ignition-proof: AISI 316L (1.4435)

Connecting parts

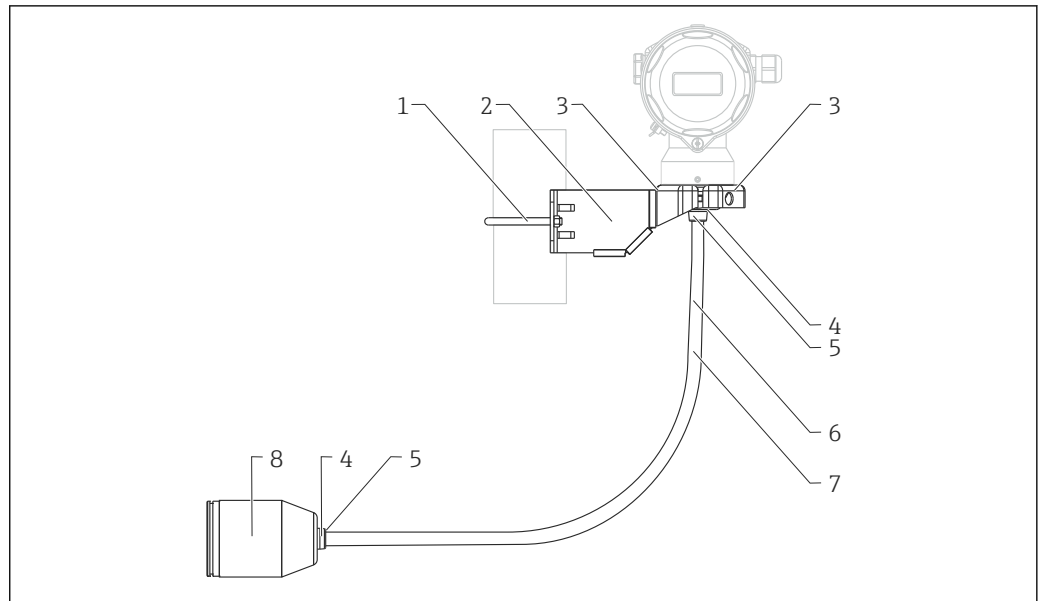

A0026172

Item number	Component part	Material
1	Mounting bracket	Bracket AISI 316L (1.4404)
2		Screw and nuts A4-70
3		Half-shells: AISI 316L (1.4404)
4	Seal for cable from separate housing	EPDM
5	Gland for cable from separate housing	AISI 316L (1.4404)
6	PE cable for separate housing	abrasion-proof cable with strain-relief Dynema members; shielded using aluminum-coated foil; insulated with polyethylene (PE-LD), black; copper wires, twisted, UV-resistant
7	FEP cable for separate housing	Abrasion-proof cable; shielded using galvanized steel wire netting; insulated with fluorinated ethylene propylene (FEP), black; copper cores, twisted, UV-resistant
8	Process connection adapter for separate housing	AISI 316L (1.4404)

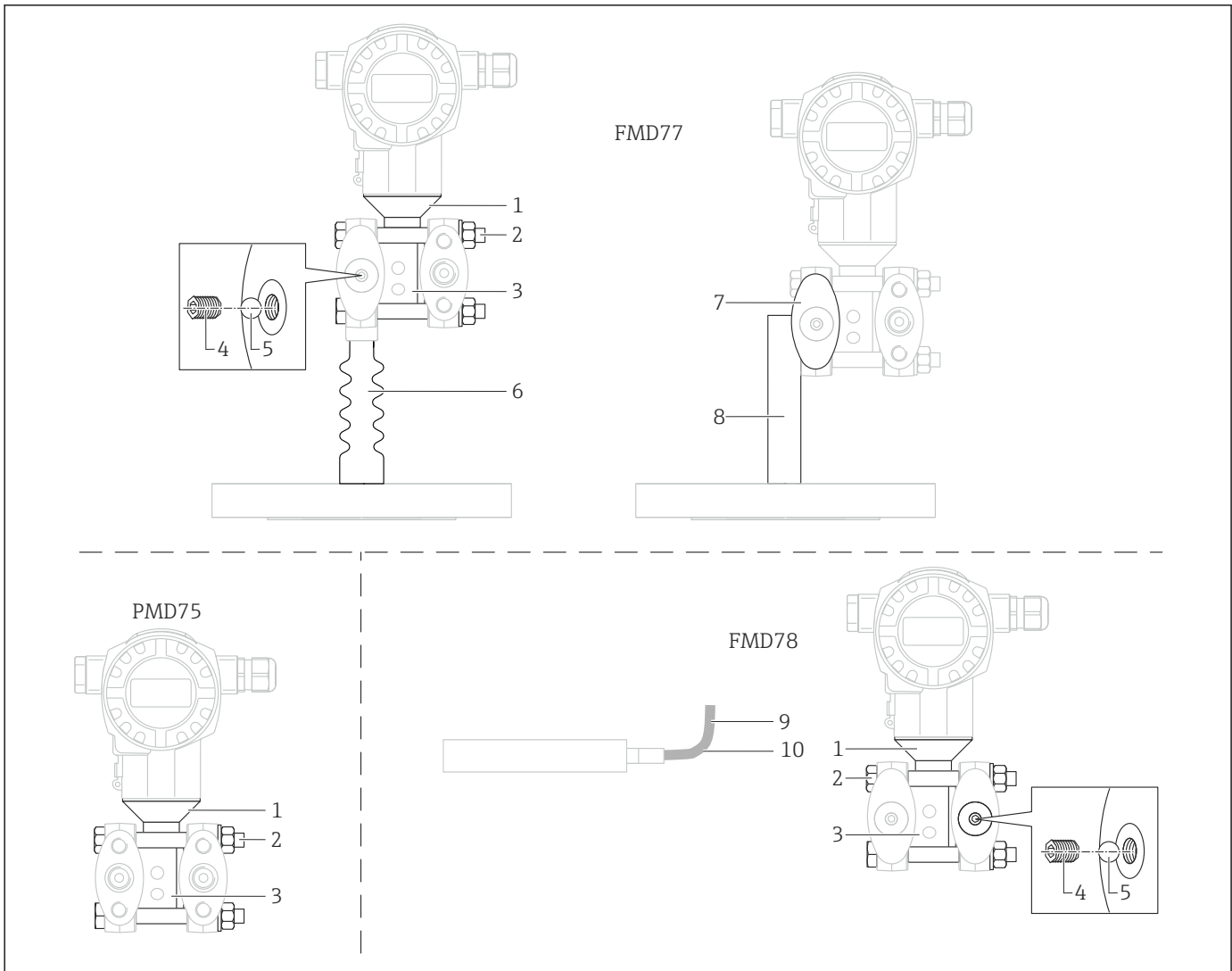

A0023955

Item number	Component part	Material
1	Connection between the housing and process connection	AISI 316L (1.4404)
2	Screw and nuts	PMD75 PN 160: Hex.-headed bolt DIN 931-M12x90-A4-70/ Hex.-headed nut DIN 934-M12-A4-70 PMD75 PN 420: Hex.-headed bolt ISO 4014-M12x90-A4/ Hex.-headed nut ISO 4032-M12-A4-bs
		FMD77, FMD78: Hex.-headed bolt DIN 931-M12x 90-A4-70/ Hex.-headed nut DIN 934-M12 -A4-70
3	Cell body	AISI 316L (1.4404)
4	Threaded pin	DIN 915 M 6x8 A2-70
5	Bearing	DIN 5401 (1.3505)
6	Temperature isolator	AISI 316L (1.4404)
7	Side flanges	AISI 316L (1.4408)
8	U-bracket	AISI 304 (1.4301)
9	Capillary	AISI 316 Ti (1.4571)
10	Flexible armor for capillary	AISI 316L (1.4404)

**Materials in contact with process**

**NOTICE**

- ▶ Process-wetted device components are listed in the "Mechanical construction" → 42 and "Ordering information" → 93sections.

**TSE Certificate of Suitability (Transmissible Spongiform Encephalopathy)**

The following applies to all device components in contact with the process:

- They do not contain any materials derived from animals.
- No additives or operating materials derived from animals are used in production or processing.

**Process connections**

- "Clamp connections" and "Hygienic process connections": AISI 316L (DIN/EN material number 1.4435)
- Endress+Hauser supplies DIN/ EN process connections with threaded connections made of stainless steel as per AISI 316L (DIN/EN material number 1.4404 (AISI 316) or 14435). With regard to their stability-temperature property, the materials 1.4404 and 1.4435 are grouped together under 13EO in EN 1092-1: 2001 Tab. 18. The chemical composition of the two materials can be identical.
- Some process connections are also available in alloy C276 (DIN/EN material number 2.4819). For this purpose see the information in the "Mechanical construction" section.
- Side flanges: 316L, C 22.8 with zinc plating or alloy C 276. The C22.8 side flanges are coated with anti-corrosion protection (zinc, chrome). In order to prevent hydrogen diffusion through the diaphragm, Endress+Hauser recommends to use side flanges made out of 316L for applications with water. Hydrogen diffusion through the diaphragm leads to measurement errors, or in extreme cases to a device failure.

**Process isolating diaphragm**

Sensor	Description	Option <sup>1)</sup>
FMD77	AISI 316L	1
	Alloy C 276 <sup>2)</sup>	2
	Monel (2.4360) <sup>2)</sup>	3
	Tantalum (UNS R05200) <sup>2)</sup>	5
	AISI 316L with gold-rhodium coating	6
	AISI 316L with 0.25 mm (0.01 in) PTFE coating (FDA 21 CFR 177.1550)	8
FMD78	AISI 316L, TempC	E
	AISI 316L	1
	Alloy C 276 <sup>2)</sup>	2
	Monel (2.4360) <sup>2)</sup>	3
	Tantalum (UNS R05200) <sup>2)</sup>	5
	AISI 316L with gold-rhodium coating	6
PMD75	AISI 316L	1
	Alloy C 276 (2.4819)	2
	Monel (2.4360)	3
	Tantalum (UNS R05200)	5
	Alloy C 276 with gold-rhodium coating	6

- 1) Product Configurator, order code for "Material of the process isolating diaphragm"
- 2) The material of the flange raised face is the same material as is used for the process isolating diaphragm. For devices with an extended diaphragm seal, the flange raised face and the barrel (extended diaphragm seal) pipe are made of 316L.

## Seals

Device	Description	Option <sup>1)</sup>
PMD75	FKM Viton	A
	PTFE (PN160bar/16MPa/2400psi)	C <sup>2)</sup>
	PTFE (PN250bar/25MPa/3625psi)	D <sup>2)</sup>
	NBR	F
	Copper seal ring	H
	Copper seal ring, O2 application, note pressure and temperature application limits	K
	FKM Viton, cleaned from oil and grease	1
	FKM Viton, cleaned for oxygen service, note pressure and temperature application limits	2
	PTFE, cleaned for oxygen service, note pressure and temperature application limits	3

- 1) Product Configurator, order code for "Seal"  
 2) Suitable for foodstuffs FDA21 CFR 177.1550

## Fill fluid

## FMD77

Description	Option <sup>1)</sup>
Silicone oil	A
Vegetable oil	D
Inert oil	F
Low-temperature oil	L
High-temperature oil	V

- 1) Product Configurator, order code for "Fill fluid"

## FMD78

Description	Option <sup>1)</sup>
...ft capillary; silicone oil	A
..... ft capillary; vegetable oil	B
..... ft capillary; high-temperature oil	C
..... ft capillary; inert oil, O2 application, observe pressure/temp. application limits	D
..... ft capillary; low-temperature oil	E
..... ft capillary, inert oil	F
..... m capillary; silicone oil	1
..... m capillary; vegetable oil	2
..... m capillary; high-temperature oil	3
..... m capillary; inert oil, O2 application, observe pressure/temp. application limits	4
..... m capillary; low-temperature oil	5
..... m capillary, inert oil	6

- 1) Product Configurator, order code for "Transmitter mounting; fill fluid"

## Operability

### Operating concept

#### Operator-oriented menu structure for user-specific tasks

- Commissioning
- Operation
- Diagnosis

#### Fast and safe commissioning

Guided menus for applications

#### Reliable operation

- Local operation possible in several languages
- Standardized operation at the device and in the operating tools
- Parameters relating to measured values can be locked/unlocked using the device's write protection switch, using the device software or via remote operation

#### Efficient diagnostics increase measurement availability

- Remedial measures are integrated in plain text
- Diverse simulation options

### Local operation

#### Functions

Function	External operation (operating keys, optional, not T17 housing)	Internal operation (electronic insert)	Onsite display (optional)
Position adjustment (zero point correction)	✓	✓	✓
Setting lower-range value and upper-range value - reference pressure present at the device	✓ (HART only)	✓ (HART only)	✓
Device reset	✓	✓	✓
Locking and unlocking parameters relevant to the measured value	—	✓	✓
Value acceptance indicated by green LED	✓	✓	✓
Switching damping on and off	✓ (only if display is connected)	✓ (HART and PA only)	✓
Configuring the bus address of the device (PA)	—	✓	✓
Switching simulation mode on and off (FOUNDATION Fieldbus)	—	✓	✓

#### Operating the device using onsite display (optional)

A 4-line liquid crystal display (LCD) is used for display and operation. The onsite display shows measured values, dialog text as well as fault and notice messages in plain text, thereby supporting the user in every stage of operation.

The display can be removed for easy operation.

The device display can be turned in 90° steps.

Depending on the installation position of the device, this makes it easy to operate the device and read the measured value.

## Functions:

- 8-digit measured value display incl. leading sign and decimal point, bar graph for
  - 4 to 20 mA HART as current display
  - PROFIBUS PA as graphic display of the standardized value of the AI block
  - FOUNDATION Fieldbus as graphic display of the transducer output.
- Simple and complete menu guidance due to breakdown of parameters into several levels and groups
- Menu guidance in up to 8 languages
- Each parameter is given a 3-digit ID number for easy navigation.
- Option for configuring the display according to individual requirements and preferences, such as language, alternating display, display of other measured values such as sensor temperature, contrast setting.
- Comprehensive diagnostic functions (fault and warning message, peak-hold indicators, etc.).
- Rapid and safe commissioning with the Quick Setup menus.

## Overview

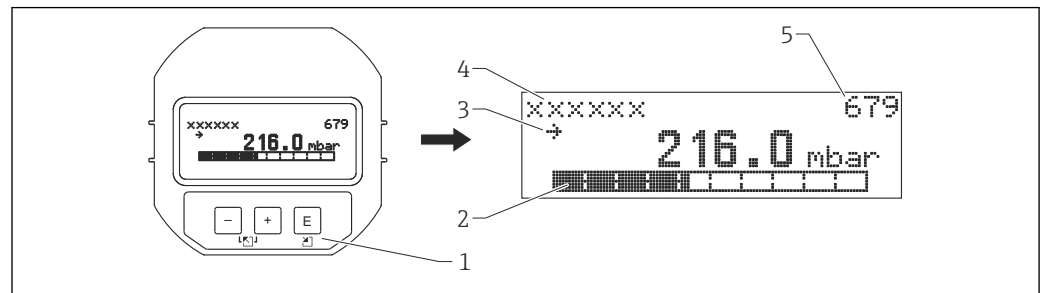

A0016498

- 1 Operating keys
- 2 Bargraph
- 3 Symbol
- 4 Header
- 5 Parameter ID number

## Operating keys on the exterior of the device

With the aluminum housing (T14), the operating keys are located either outside on the housing, under the protection cap or inside on the electronic insert. With the stainless steel housing (T17), the operating keys are always located inside the housing on the electronic insert.

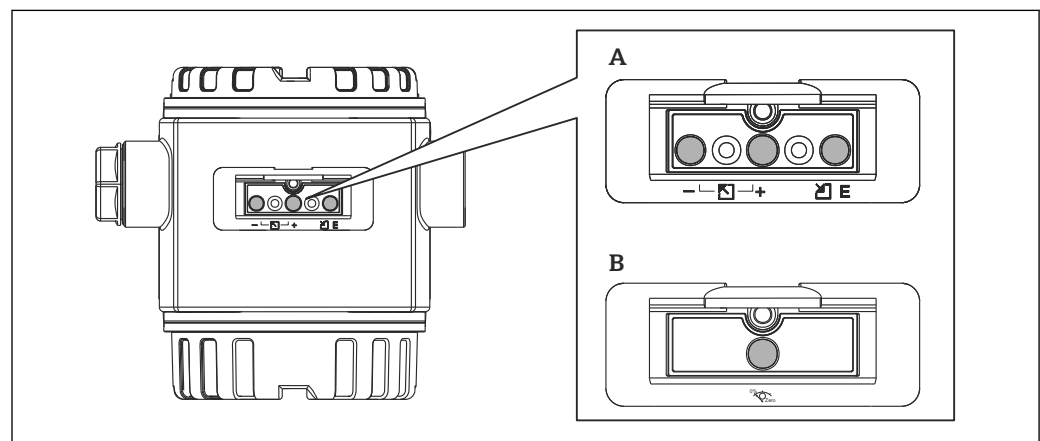

A0020030

- A 4 to 20 mA HART
- B PROFIBUS PA and FOUNDATION Fieldbus

The operating keys located externally on the device work on the Hall sensor principle. As a result, no additional openings are required in the device. This guarantees:

- Complete protection against environmental influences such as moisture and contamination.
- Simple operation without any tools.
- No wear.

Ordering information:

Product Configurator, order code for "Output, operation"

**Operating keys and elements located internally on the electronic insert**

Ordering information:

Product Configurator, order code for "Output, operation"

*HART*

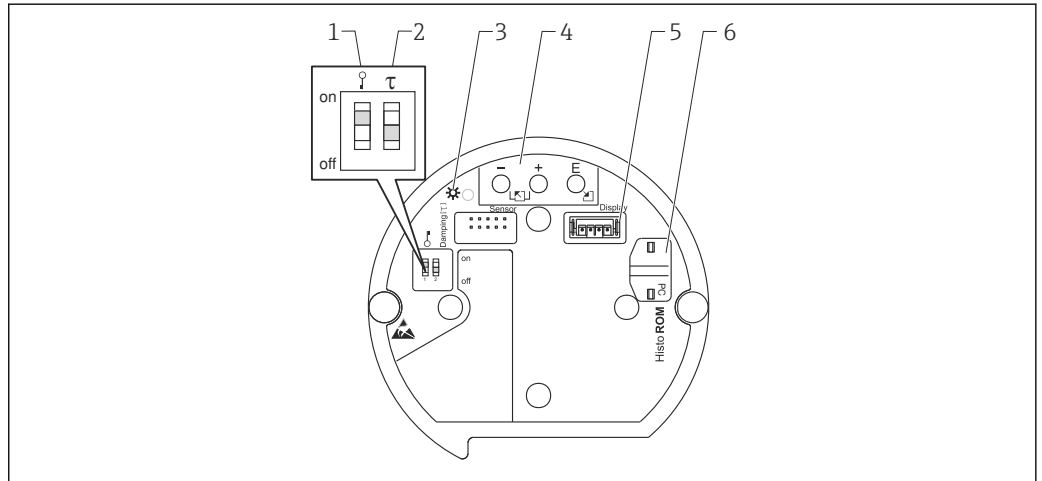

A0020031

- 1 DIP switch for locking/unlocking parameters relevant to the measured value
- 2 DIP switch for switching damping on/off
- 3 Green LED to indicate value being accepted
- 4 Operating keys
- 5 Slot for optional display
- 6 Slot for optional HistoROM®/M-DAT

*PROFIBUS PA*

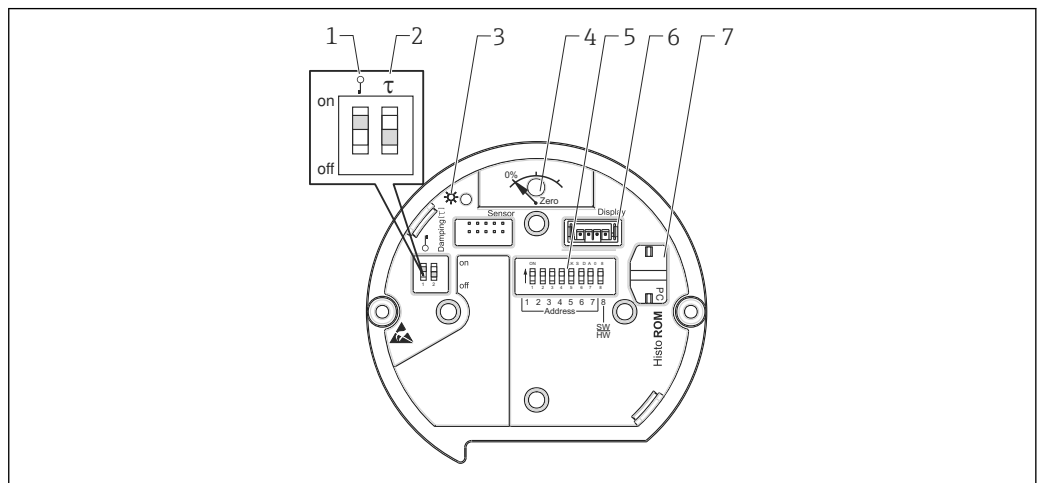

A0020032

- 1 DIP switch for locking/unlocking parameters relevant to the measured value
- 2 DIP switch for switching damping on/off
- 3 Green LED to indicate value being accepted
- 4 Key for position adjustment and device reset
- 5 DIP switch for bus address
- 6 Slot for optional display
- 7 Slot for optional HistoROM®/M-DAT

FOUNDATION Fieldbus

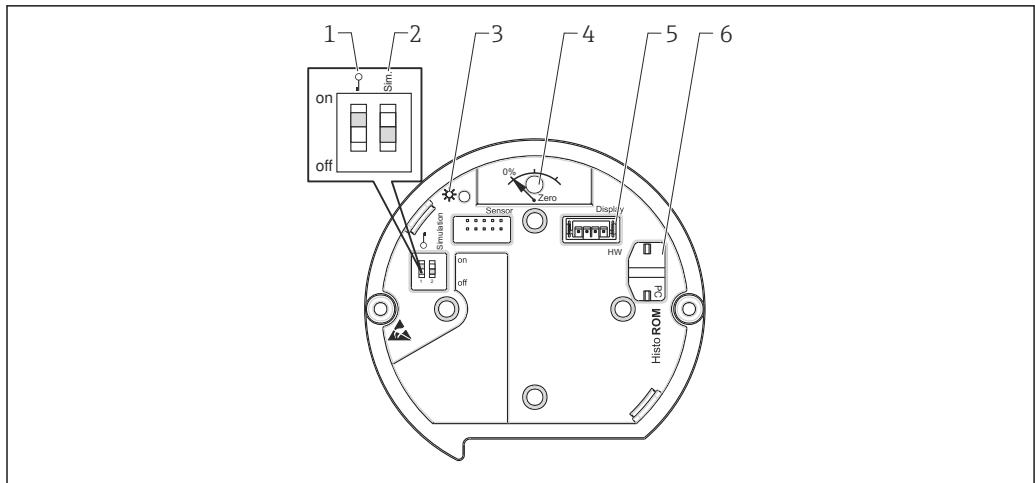

A0020033

- 1 DIP switch for locking/unlocking parameters relevant to the measured value
- 2 DIP switch for simulation mode on/off
- 3 Green LED to indicate value being accepted
- 4 Key for position adjustment and device reset
- 5 Slot for optional display
- 6 Slot for optional HistoROM®/M-DAT

Remote operation

All software parameters are accessible depending on the position of the write protection switch on the device.

Hardware and software for remote operation	HART	PROFIBUS PA	FOUNDATION Fieldbus
FieldCare	✓	✓	✓
FieldXpert SFX100	✓	—	✓
NI-FBUS Configurator	—	—	✓
HistoROM®/M-DAT	✓	✓	✓

FieldCare

FieldCare is an Endress+Hauser asset management tool based on FDT technology. With FieldCare, you can configure all Endress+Hauser devices as well as devices from other manufacturers that support the FDT standard.

FieldCare supports the following functions:

- Configuration of transmitters in offline and online mode
- Loading and saving device data (upload/download)
- HistoROM®/M-DAT analysis
- Documentation of the measuring point

Connection options:

- HART via Commubox FXA195 and the USB port on a computer
- PROFIBUS PA via segment coupler and PROFIBUS interface card
- Service interface with Commubox FXA291 and ToF adapter FXA291 (USB).

For further information please contact your local Endress+Hauser Sales Center.

Field Xpert SFX100

Field Xpert is an industrial PDA with integrated 3.5" touchscreen from Endress+Hauser based on Windows Mobile. It offers wireless communication via the optional VIATOR Bluetooth modem from Endress+Hauser. Field Xpert also works as a stand-alone device for asset management applications. For details, refer to BA00060S/04/EN.

Commubox FXA195

For intrinsically safe HART communication with FieldCare via the USB interface. For details refer to TI00404F/00/EN.

### Commubox FXA291

The Commubox FXA291 connects Endress+Hauser field devices with a CDI interface (=Endress+Hauser Common Data Interface) to the USB interface of a personal computer or a notebook. For details refer to TI00405C/07/EN.



For the following Endress+Hauser devices you need the "ToF adapter FXA291" as an additional accessory:

- Cerabar S PMC71, PMP7x
- Deltabar S PMD7x, FMD7x
- Deltapilot S FMB70

### ToF adapter FXA291

The ToF adapter FXA291 connects the Commubox FXA291 with devices of the ToF platform, pressure equipment and Gammapilot via the USB interface of a personal computer or a notebook. For details refer to KA00271F.

### Profiboard

For connecting a PC to PROFIBUS.

### Proficard

For connecting a laptop to PROFIBUS

### FF configuration program

FF configuration program, such as NI-FBUS Configurator, to

- connect devices with "FOUNDATION Fieldbus signal" into an FF network
- set FF-specific parameters

*Remote operation via the NI-FBUS Configurator:*

The NI-FBUS Configurator is an easy-to-use graphical environment for creating linkages, field-based control loops and schedules based on the FOUNDATION Fieldbus concept.

You can use the NI-FBUS Configurator to configure a fieldbus network as follows:

- Set block and device tags
- Set device addresses
- Create and edit function block control strategies (function block applications)
- Configure vendor-defined function and transducer blocks
- Create and edit schedules
- Read and write to function block control strategies (function block applications)
- Invoke Device Description (DD) methods
- Display DD menus
- Download a configuration
- Verify a configuration and compare it to a saved configuration
- Monitor a downloaded configuration
- Replace a virtual device by a real device
- Save and print a configuration

---

### HistoROM®/M-DAT (optional)

HistoROM®/M-DAT is a memory module which can be attached to every electronic insert. HistoROM®/M-DAT can be retrofitted at any stage (order number: 52027785).

The benefits for you

- Quick and safe commissioning of the same measuring points by copying the configuration data of one transmitter to another transmitter.
- Reliable process monitoring thanks to cyclical recording of pressure and sensor temperature measured values.
- Simple diagnosis by recording diverse events such as alarms, configuration changes, counters for measuring range undershoot and overshoot for pressure and temperature as well as user limit overshoot and undershoot for pressure and temperature etc.
- Analysis and graphic evaluation of the events and process parameters via software (contained in scope of supply).

A CD with an Endress+Hauser operating program is also included in the scope of delivery. You can copy data from one transmitter to another transmitter when operating a FOUNDATION Fieldbus device via an FF configuration program. You need the Endress+Hauser FieldCare operating program and the Commubox FXA291 service interface and the ToF adapter FXA291 to be able to access the data and events saved in the HistoROM®/M-DAT.

Ordering information:

Product Configurator, order code for "Additional options:", version "N" or

Product Configurator, order code for "Application package:", option "EN" or  
as a separate accessory (part no.: 52027785).



For further information please contact your local Endress+Hauser Sales Center.

---

### System integration

The device can be given a tag name (max. 8 alphanumeric characters).

Description	Option <sup>1)</sup>
Measuring point (TAG), see additional spec.	Z1
Bus address, see additional spec.	Z2

1) Product Configurator, order code for "Marking"

## Planning instructions, diaphragm seal systems

### NOTICE

#### Incorrect sizing/ordering of diaphragm seal systems

The performance and the permitted range of application of a diaphragm seal system depend on the process isolating diaphragm used, the filling oil, the coupling, the unit design and on the process and ambient conditions present in the individual application.

- ▶ To help you select the right diaphragm seal system for your applications, Endress+Hauser provides its customers with the free "Applicator Sizing Diaphragm Seal" tool, which is available on DVD or at "www.endress.com/applicator".

- 1 My Applicator - configuration of the Applicator settings
- 2 Applicator help
- 3 Mouse-over help - hover the cursor over these fields for brief information

For more detailed information or the layout of the optimum diaphragm seal solution for your application, please contact your local Endress+Hauser Sales Center.

### Applications

Diaphragm seal systems should be used if the process and the device should be separated.

Diaphragm seal systems offer clear advantages in the following instances:

- In the case of extreme process temperatures
- For aggressive media
- In the case of process media that crystallize
- In the case of corrosive or highly various process media or process media with solids content
- In the case of heterogeneous and fibrous process media
- If extreme measuring point cleaning is necessary, or for very humid mounting locations
- If the measuring point is exposed to severe vibrations
- For mounting locations that are difficult to access

**Design and operation mode**

Diaphragm seals are separating equipment between the measuring system and the process.

A diaphragm seal system consists of:

- A diaphragm seal in a one-sided system, e.g. FMD77 or two diaphragm seals in a two-sided system, e.g. FMD78
- One capillary tube or two capillary tubes
- Fill fluid
- A differential pressure transmitter

The process pressure acts via the process isolating diaphragm of the diaphragm seal on the liquid-filled system, which transfers the process pressure via the capillary tube onto the sensor of the differential pressure transmitter.

Endress+Hauser delivers all diaphragm seal systems as welded versions. The system is hermetically sealed, which ensures the highest reliability.

The diaphragm seal determines the application range of the system by:

- The process isolating diaphragm diameter
- The process isolating diaphragm stiffness and material
- The design (oil volume)

**diameter of the process isolating diaphragm**

The greater the diameter of the process isolating diaphragm (less stiff), the smaller the temperature effect on the measurement result.

**Stiffness of the process isolating diaphragm**

The stiffness depends on the diameter of the process isolating diaphragm, the material, any existing coating and the thickness and shape of the process isolating diaphragm. The process isolating diaphragm thickness and the shape are determined by the design. The stiffness of a process isolating diaphragm of a diaphragm seal influences the temperature operating range and the measuring error caused by temperature effects.

*The new TempC diaphragm: Highest accuracy and process safety in pressure and differential pressure measurement with diaphragm seals*

To measure even more precisely in such applications and to increase process safety, Endress+Hauser has developed the TempC diaphragm based on a completely revolutionary technology. This diaphragm guarantees the highest level of accuracy and process safety in diaphragm seal applications.

- The very low temperature effect minimizes the influence of fluctuations of both process and ambient temperatures, thus guaranteeing accurate and stable measurements. Measurement inaccuracies caused by temperature are reduced to a minimum.
- The TempC diaphragm can be used at temperatures between  $-40\text{ °C}$  ( $-40\text{ °F}$ ) and  $+250\text{ °C}$  ( $+482\text{ °F}$ ). This guarantees maximum process safety even for very long sterilization and cleaning cycles (SIP/CIP) in tanks and pipes at high temperatures.
- Thanks to the TempC diaphragm, smaller dimension process connections are possible. With a smaller process connection, the new diaphragm measures at least as accurately as a conventional diaphragm with a larger diameter.
- Short recovery times after temperature shocks mean less downtime during batch processes and therefore a far higher level of availability of the production facilities.
- In addition, the TempC diaphragm excels in terms of its improved hygienic cleanability and its insensitivity to substantial changes in the pressure load.

Ordering information:

See the Product Configurator for the individual process connection and the choice of process isolating diaphragm.

Selection in the Applicator:

Under "Transmitter data" in the "Diaphragm material" field.

**Capillary**

Diaphragm seals are used with the following capillary internal diameters as standard:

- $\leq$  DN 50: 1 mm (0.04 in)
- $>$  DN 50: 2 mm (0.08 in)

The capillary tube influences the thermal change, the ambient temperature operating range and the response time of a diaphragm seal system as a result of its length and internal diameter.

### Filling oil

When selecting the filling oil, the media and ambient temperature as well as the operating pressure are of crucial importance. Observe the temperatures and pressures during commissioning and cleaning. A further selection criterion is the compatibility of the filling oil with the requirements of the process media. For this reason, only filling oils that are harmless to health may be used in the food industry, such as vegetable oil or silicone oil (see also the following section on "diaphragm seal filling oils").

The filling oil used influences the thermal change, the temperature operating range of a diaphragm seal system and the response time. A temperature change results in a volume change of the filling oil. The volume change is dependent on the expansion coefficient and on the volume of the filling oil at calibration temperature (constant in range: +21 to +33 °C (+70 to +91 °F)). The application range can be extended by a filling oil with a lower expansion coefficient and a shorter capillary.

For example, the filling oil expands in the event of a temperature increase. The additional volume presses against the process isolating diaphragm of a diaphragm seal. The stiffer a diaphragm is, the greater its return force, which counteracts a volume change and acts on the measuring cell together with the operating pressure, thus shifting the zero point.

### Differential pressure transmitter

The differential pressure transmitter influences the temperature operating range, the TK zero point and the response time as a result of the volume of its side flange and as a result of its volume change. The volume change is the volume that has to be shifted to pass through the complete measuring range.

Differential pressure transmitters from Endress+Hauser are optimized with regard to the minimum volume change and side flange.

### Diaphragm seal filling oils

Filling oil	Permitted temperature range <sup>1)</sup> at 0.05 bar (0.725 psi) $\leq p_{abs} \leq$ 1 bar (14.5 psi)	Permitted temperature range <sup>1)</sup> at $p_{abs} \geq$ 1 bar (14.5 psi)	Density [g/cm <sup>3</sup> ] / [SGU]	Viscosity [mm <sup>2</sup> /s] / [cSt] at 25 °C (77 °F)	Expansion coefficient <sup>2)</sup> [1/K]	Notes	Option <sup>3)</sup>
Silicone oil	-40 to +180 °C (-40 to +356 °F)	-40 to +250 °C (-40 to +752 °F)	0.96	100	0.00096	(Suitable for use in food FDA 21 CFR 175.105)	FMD77: A FMD78: A, 1
High-temperature oil	-10 to +200 °C (+14 to +392 °F)	-10 to +400 °C (+14 to +752 °F) <sup>4) 5) 6)</sup>	1.00	150	0.00096	(High temperatures)	FMD77: V FMD78: C, 3
Inert oil	-40 to +80 °C (-40 to +176 °F)	-40 to +175 °C (-40 to +347 °F)	1.87	27	0.000876	(For ultrapure gas and oxygen applications)	FMD77: F FMD78: D, 4
Vegetable oil	-10 to +120 °C (+14 to +248 °F)	-10 to +200 °C (+14 to +392 °F)	0.94	9.5	0.00101	(Suitable for use in food FDA 21 CFR 172.856)	FMD77: D FMD78: B, 2
Low-temperature oil	-70 to +80 °C (-94 to +176 °F)	-70 to +180 °C (-94 to +356 °F)	0.92	4.4	0.00108	(Low temperatures)	FMD77: L FMD78: E, 5

1) Observe temperature limits of the device and the system.

2) For the thermal change of the diaphragm seal as well as other important technical performance characteristics, please refer to the "Applicator Sizing Diaphragm Seal" selection tool.

3) Product Configurator, order code for "Fill fluid"

4) 325 °C (617 °F) at 1 bar (14.5 psi) absolute pressure.

5) 350 °C (662 °F) at 1 bar (14.5 psi) absolute pressure (max. 200 hours).

6) 400 °C (752 °F) at 1 bar (14.5 psi) absolute pressure (max. 10 hours).

### Operating temperature range

The operating temperature range of a diaphragm seal system depends on the fill fluid, capillary length and internal diameter, process temperature and oil volume of the diaphragm seal.

The application range can be extended by using a filling oil with a smaller expansion coefficient and a shorter capillary.

**Response time**

The viscosity of the filling oil, the capillary length and the capillary internal diameter influence the frictional resistance. The greater the frictional resistance, the longer the response time. Furthermore, the volume change of the measuring cell influences the response time. The lower the volume change of the measuring cell, the less filling oil has to be shifted in the diaphragm seal system.

The following diagram shows typical response times (T90) for the various filling oils dependent on the measuring cell and the capillary internal diameter. The values given are in seconds per meter of capillary length and must be multiplied by the actual length of the capillary. The response time of the transmitter must also be taken into consideration.

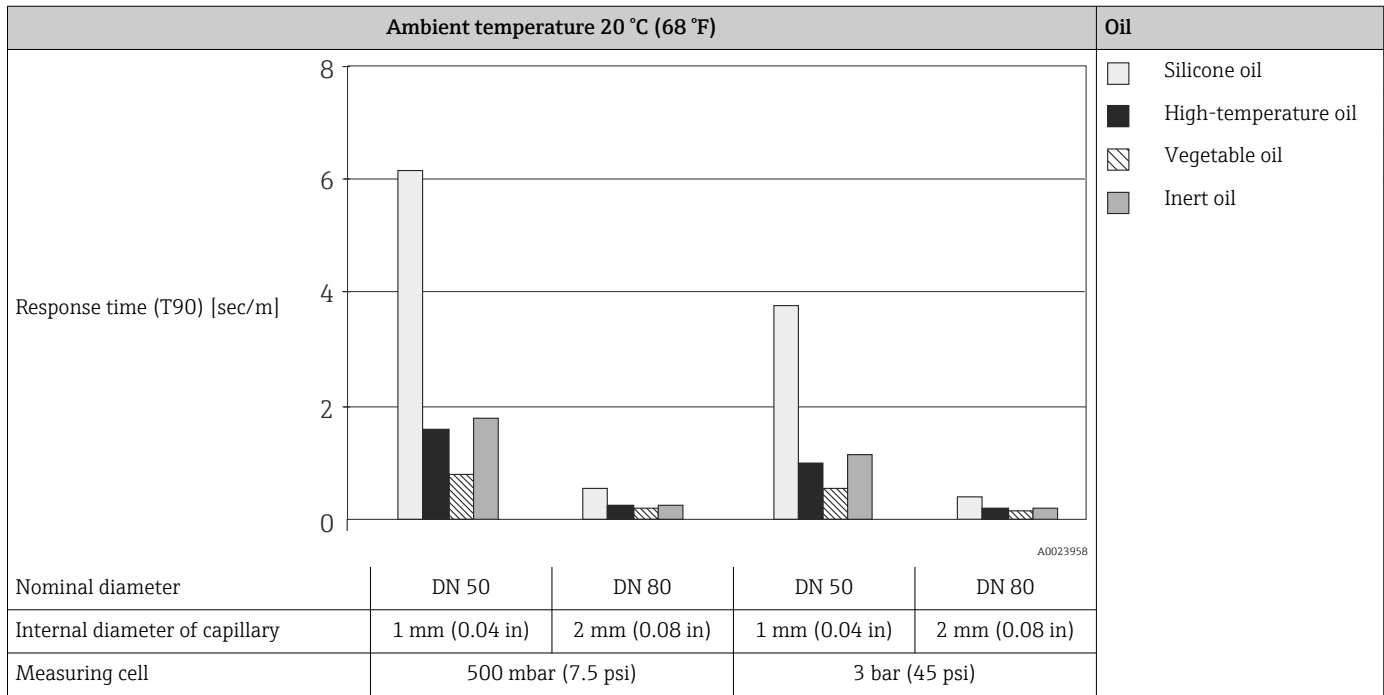

Presentation of the response time (T90%)

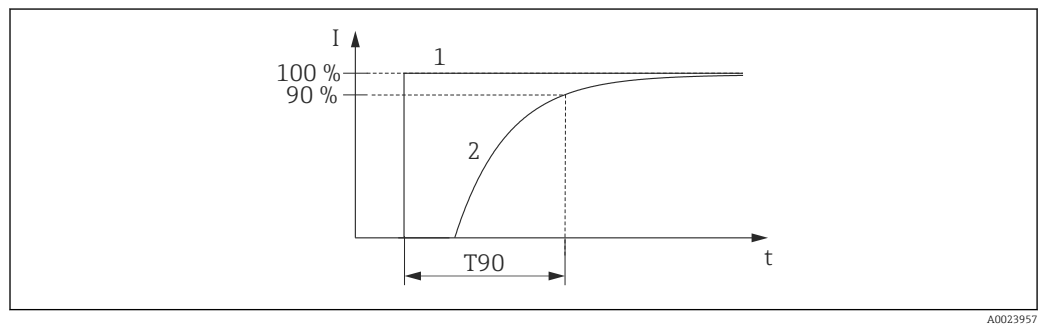

- 1 Jump in pressure
- 2 Output signal

Minimize response time by	Comments
Larger capillary internal diameter	The temperature effect increases with increasing diameter.
Shorter capillaries	-
Filling oil with lower viscosity	<ul style="list-style-type: none"> <li>▪ Observe compatibility of the filling oil with the process media.</li> <li>▪ Observe the filling oil operating limits.</li> </ul>

**Information on cleaning**

- Endress+Hauser provides flushing rings as an accessory to enable cleaning of the process isolating diaphragm without removing the transmitter from the process. For further information please contact your local Endress+Hauser Sales Center.
- We recommend you perform CIP (cleaning in place (hot water)) before SIP (sterilization in place (steam)) for pipe diaphragm seals. A frequent use of sterilization in place (SIP) will increase the stress on the process isolating diaphragm. Under unfavorable circumstances in the long term view we cannot exclude that a frequent temperature change could lead to a material fatigue of the process isolating diaphragm and possibly to a leakage.

**Installation instructions**

**Diaphragm seal systems**

- The diaphragm seal together with the transmitter form a closed, calibrated system, which is filled through ports in the diaphragm seal and in the measuring system of the transmitter. These ports are sealed and must not be opened.
- In the case of devices with diaphragm seals and capillaries, the zero point shift caused by the hydrostatic pressure of the filling liquid column in the capillaries must be taken into account when selecting the measuring cell. If a measuring cell with a small measuring range is selected, the sensor nominal range can be overdriven as a result of position adjustment (see the figure and the example below).
- For devices with a capillary a suitable fastening device (mounting bracket) is recommended.
- If a mounting bracket is used, sufficient strain relief must be ensured for the capillaries in order to prevent them from buckling (bending radius  $\geq 100$  mm (3.94 in)).
- For more detailed installation instructions, Endress+Hauser provides its customers with the free "Applicator Sizing Diaphragm Seal" tool, which is available on CD or can be downloaded online at "www.endress.com/applicator".

Selecting the measuring cell (observe the hydrostatic pressure of the filling liquid column in the capillaries!)

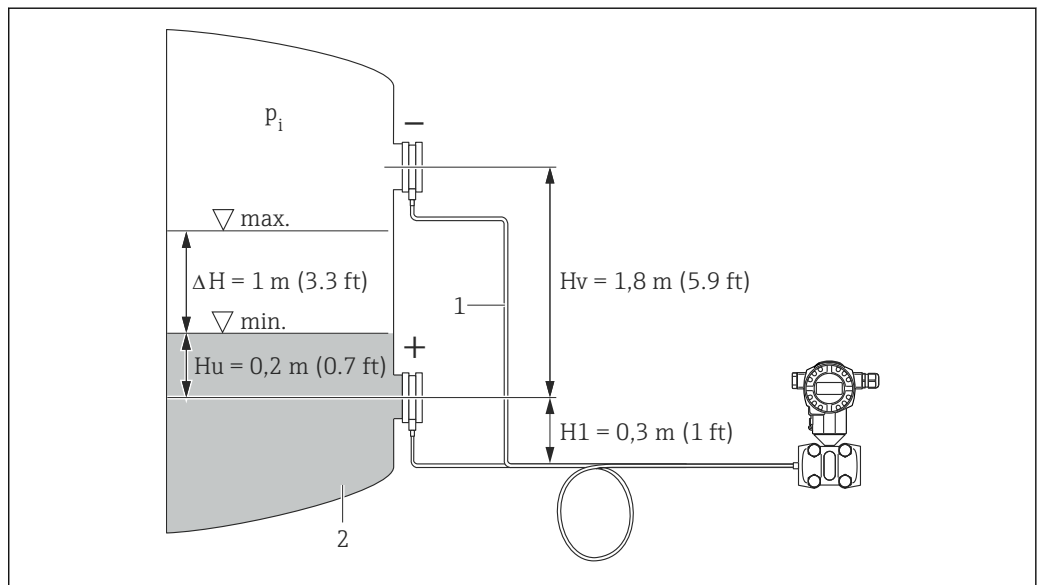

- 1 Capillary with silocon oil:  $\rho_{Fl} = 0.96 \text{ kg (2.12 lb) dm}^3$
- 2 Container with water:  $\rho_M = 1.0 \text{ kg (2.21 lb) dm}^3$

Pressure on the negative side of the differential pressure transmitter (p<sub>-</sub>) when the container is empty (minimum level):

$$\begin{aligned}
 p_- &= p_{HV} + p_{H1} = H_v \cdot \rho_{Fl} \cdot g + H_1 \cdot \rho_{Fl} \cdot g + p_i \\
 &= 1,8 \text{ m} \cdot 0,96 \frac{\text{kg}}{\text{dm}^3} \cdot 9,81 \frac{\text{m}}{\text{s}^2} + 0,3 \text{ m} \cdot 0,96 \frac{\text{kg}}{\text{dm}^3} \cdot 9,81 \frac{\text{m}}{\text{s}^2} + p_i \\
 &= 197,77 \text{ mbar} + p_i
 \end{aligned}$$

Pressure on the positive side of the differential pressure transmitter ( $p_+$ ) when the container is empty (minimum level):

$$\begin{aligned}
 p_+ &= p_{HU} + p_{H1} = H_u \cdot \rho_M \cdot g + H_1 \cdot \rho_{F1} \cdot g + p_i \\
 &= 0,2 \text{ m} \cdot 1 \frac{\text{kg}}{\text{dm}^3} \cdot 9,81 \frac{\text{m}}{\text{s}^2} + 0,3 \text{ m} \cdot 0,96 \frac{\text{kg}}{\text{dm}^3} \cdot 9,81 \frac{\text{m}}{\text{s}^2} + p_i \\
 &= 47,87 \text{ mbar} + p_i
 \end{aligned}$$

A0023981

Differential pressure at the transmitter ( $\Delta p_{\text{transmitter}}$ ) when the container is empty:

$$\begin{aligned}
 \Delta p_{\text{Transmitter}} &= p_+ - p_- \\
 &= 47,87 \text{ mbar} - 197,77 \text{ mbar} \\
 &= -149,9 \text{ mbar}
 \end{aligned}$$

A0023982

Result:

When the container is full, the differential pressure at the differential pressure transmitter would be  $-51.80 \text{ mbar}$  ( $-0.762 \text{ psi}$ ). When the tank is empty, the differential pressure is  $-149.90 \text{ mbar}$  ( $-2.2485 \text{ psi}$ ). A  $500 \text{ mbar}$  ( $7.5 \text{ psi}$ ) measuring cell is thus required for this application.

### Capillary

In order to obtain more precise measurement results and to avoid a defect in the device, mount the capillaries as follows:

- vibration-free (in order to avoid additional pressure fluctuations)
- not in the vicinity of heating or cooling lines
- insulate if the ambient temperature is below or above the reference temperature
- with a bending radius  $\geq 100 \text{ mm}$  ( $3.94 \text{ in}$ )
- Sufficient strain relief must be ensured for diaphragm seal systems with capillaries in order to prevent the capillaries from buckling (bending radius  $\geq 100 \text{ mm}$  ( $3.94 \text{ in}$ )).
- In the case of devices with diaphragm seals and capillaries, the zero point shift caused by the hydrostatic pressure of the filling liquid column in the capillaries must be taken into account when selecting the measuring cell. If a measuring cell with a small measuring range is selected, a position adjustment can cause range violation.

**Heat insulation – FMD77**

The FMD77 must only be insulated up to a certain height. The maximum permitted insulation height applies to an insulation material with a heat conductivity  $\leq 0.04 \text{ W}/(\text{m} \times \text{K})$  and to the maximum permitted ambient and process temperature. The data were determined under the most critical application "quiescent air".

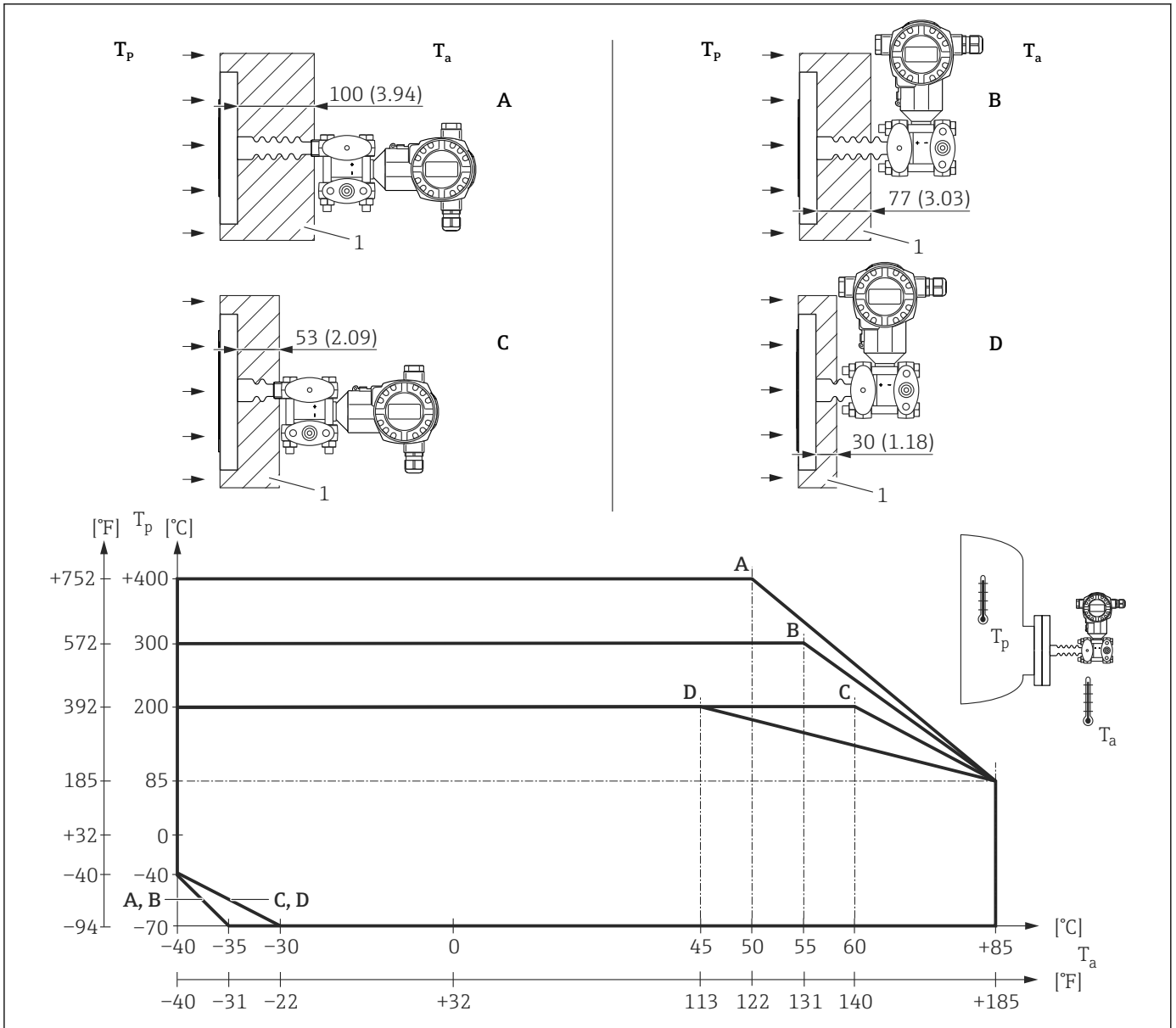

A0025889

1 Insulation material

Without insulation, the ambient temperature decreases by 5 K.

Item	Design	Temperature isolator	Option <sup>1)</sup>
A	Transmitter horizontal	long	MA <sup>2)</sup>
B	Transmitter vertical	long	MB
C	Transmitter horizontal	short	MC
D	Transmitter vertical	short	MD

1) Product Configurator, order code for "Design; Temperature isolator"

2) Standard

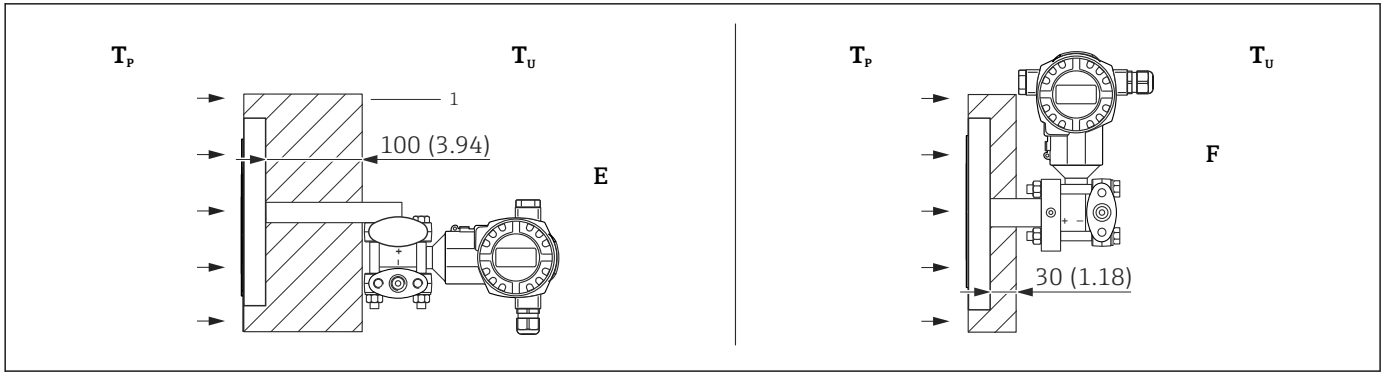

A0023984

1 Insulation material

Item	Design	Ambient temperature $T_u$	Process temperature $T_p$	Option <sup>1)</sup>
E	U-bracket, Transmitter horizontal (for devices which require a CRN approval)	$\leq 70\text{ }^\circ\text{C}$ (158 °F)	Max. 350 °C (662 °F) depending on diaphragm seal filling oil used	<sup>2)</sup>
F	Compact version, Transmitter vertical	-	-	5, 6, 7, 8

- 1) Product Configurator, order code for "Process connection"
- 2) In combination with CSA approval.

**Vacuum applications**

**Installation instructions**

For applications under vacuum, Endress+Hauser recommends mounting the pressure transmitter below the lower diaphragm seal. This prevents a vacuum load of the diaphragm seal caused by the presence of filling oil in the capillaries.

When the pressure transmitter is mounted above the lower diaphragm seal, the maximum height difference H1, in accordance with the following illustrations, must not be exceeded:

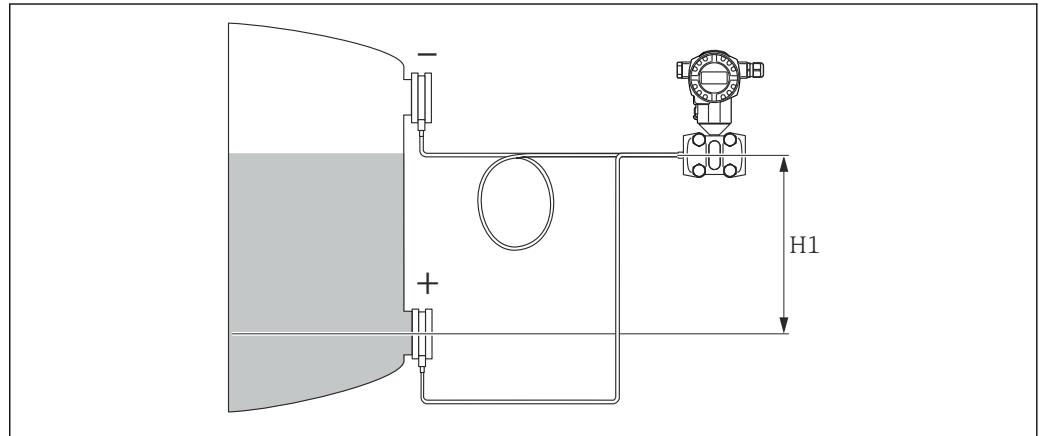

A0023983

The maximum height difference is dependent on the density of the filling oil and the lowest pressure that is ever allowed to occur at the diaphragm seal on the positive side (empty container), see the following illustration:

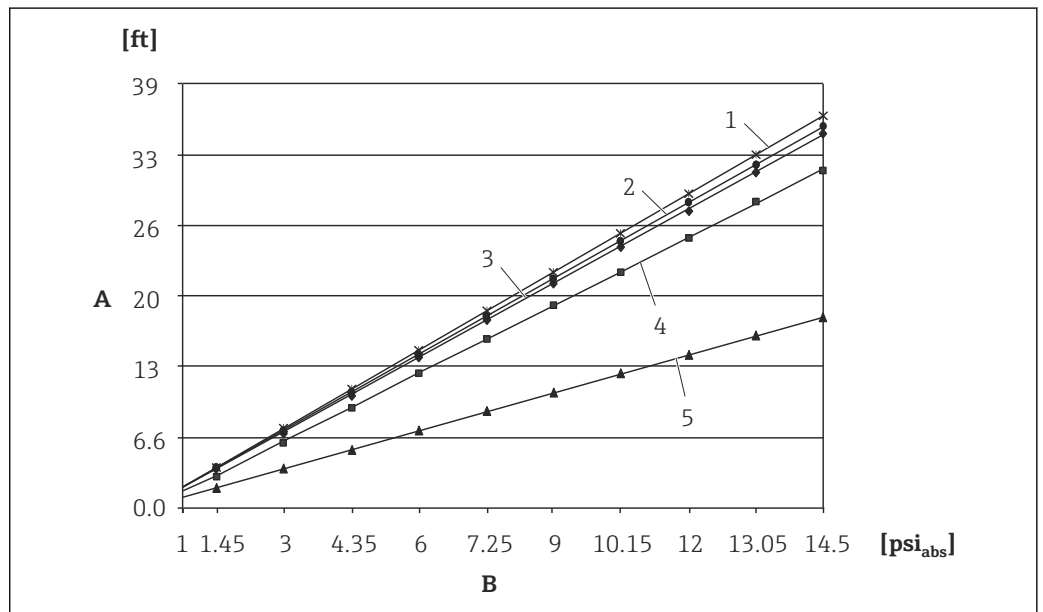

A0023986-EN

- A Height difference H1
- B Pressure at diaphragm seal
- 1 Low-temperature oil
- 2 Vegetable oil
- 3 Silicone oil
- 4 High-temperature oil
- 5 Inert oil

## Certificates and approvals

<b>CE mark</b>	The device meets the legal requirements of the relevant EC directives. Endress+Hauser confirms that the device has been successfully tested by applying the CE mark.
<b>C-tick mark</b>	The measuring system complies with EMC requirements of the "Australian Communications and Media Authority (ACMA)".
<b>Ex approvals</b>	<ul style="list-style-type: none"> <li>▪ ATEX</li> <li>▪ FM</li> <li>▪ CSA</li> <li>▪ NEPSI</li> <li>▪ IECEX</li> <li>▪ GOST on request</li> <li>▪ Also combinations of different approvals</li> </ul> <p>All explosion protection data are given in separate documentation which is available upon request. The Ex documentation is supplied as standard with all devices approved for use in explosion hazardous areas →  97.</p>

### Suitable for hygiene applications

All materials in contact with foodstuffs comply with framework regulation (EC) 1935/2004. The device is available with hygienic process connections (overview: see order code).

#### CAUTION

#### Contamination in the process!

Risk of contamination if incorrect seals and parts are used!

- ▶ To avoid the risk of contamination, when installing the device comply with the design principles of EHEDG, Guideline 37 "Hygienic Design and Application of Sensors" and Guideline 16 "Hygienic Pipe Couplings".
- ▶ Suitable assemblies and seals must be used to ensure hygienic design in accordance with 3-A SSI and EHEDG specifications.
- ▶ The leak-proof connections can be cleaned with the cleaning methods typical of this industry (CIP and SIP). Attention must be paid to the pressure and temperature specifications of the sensor and process connections for CIP and SIP processes (clean in place/sterilize in place).

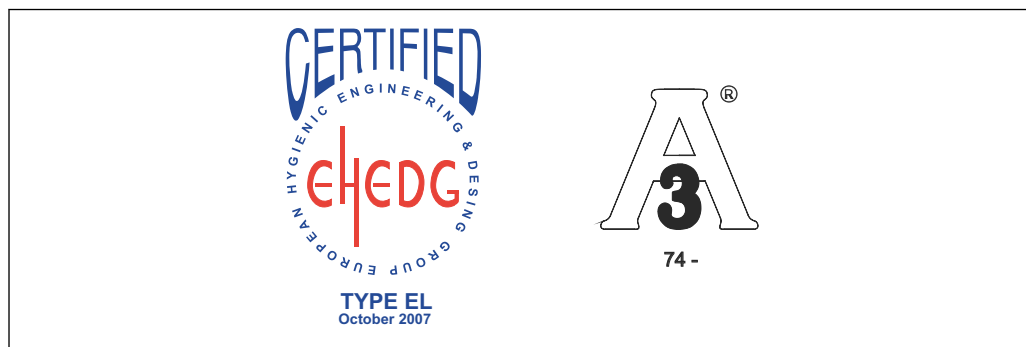

A0026782

 The gap-free connections can be cleaned of all residue using the usual cleaning methods within this industry.

### Functional safety SIL/ IEC 61508 Declaration of Conformity (optional)

The Deltabar S with 4 to 20 mA output signal has been developed to IEC 61508 standard. The device can be used for flow, level and differential pressure monitoring up to SIL 3. For a detailed description of the safety functions with Deltabar S, settings and characteristic quantities for functional safety, please refer to the "Functional Safety Manual - Deltabar S" SD00189P.

For devices up to SIL 3 / IEC 61508 Declarations of Conformity see:

Ordering information:

Product Configurator, order code for "Additional options 1", version "E"

### Overfill protection

WHG (see document ZE00259P/00/DE)

Ordering information:

Product Configurator, order code for "Approval" option "F".

**CRN approval**

Some device versions have CRN approval. A CRN-approved process connection with a CSA approval must be ordered for a CRN-approved device. These devices are fitted with a separate plate bearing the registration number CRN OF10524.5C .

Ordering information:

Product Configurator, order code for "Process connection; material" and

Product Configurator, order code for "Approval"

**Other standards and guidelines**

The applicable European guidelines and standards can be found in the relevant EU Declarations of Conformity. The following were also applied:

**DIN EN 60770 (IEC 60770):**

Transmitters for use in industrial-process control systems. Part 1: Methods for operating performance evaluation

**DIN 16086:**

Electrical pressure measuring instruments, pressure sensors, pressure transmitters, pressure measuring instruments, concepts, specifications on data sheets

**EN 61326-X:**

EMC product family standard for electrical equipment for measurement, control and laboratory use.

**EN 60529:**

Degrees of protection provided by enclosures (IP code)

**Pressure Equipment Directive (PED)**

The device corresponds to Article 3 (3) of the EC directive 97/23/EC (Pressure Equipment Directive) and has been designed and manufactured in accordance with good engineering practice.

The following also applies:

- FMD78 with pipe diaphragm seal  $\geq 1.5$ "/PN40:  
Suitable for stable gases in group 1, category II
- PMD75, PN 420  
Suitable for stable gases in group 1, category I

**Marine approval**

- GL: FMD78, PMD75
- ABS: FMD78, PMD75

Ordering information:

Product Configurator, order code for "Additional options 1" or "Additional options 2", version "S".

**Classification of process sealing between electrical systems and (flammable or combustible) process fluids in accordance with ANSI/ISA 12.27.01**

Endress+Hauser devices are designed in accordance with ANSI/ISA 12.27.01. allowing the user to waive the use and save the cost of installing external secondary process seals in the conduit as required by the process sealing sections of ANSI/NFPA 70 (NEC) and CSA 22.1 (CEC). These instruments comply with the North American installation practice and provide a very safe and cost-saving installation for pressurized applications with hazardous fluids. Please refer to the following table for the seal class assigned (single seal or dual seal):

Device	Approval	Single seal MWP
PMD75	CSA C/US IS, XP	420 bar (6 300 psi)
FMD77	CSA C/US IS, XP	160 bar (2 400 psi)
FMD78	CSA C/US IS, XP	160 bar (2 400 psi)

Further information can be found in the control drawings of the relevant devices.

## Inspection certificate

Description	FMD77	FMD78	PMD75	Option
3.1 Material documentation, wetted metal parts, EN10204-3.1 inspection certificate	✓	✓	✓	B <sup>1)</sup>
3.1 Material documentation, wetted metal parts, EN10204-3.1 inspection certificate	✓	✓	✓	JA <sup>2)</sup>
EN10204-3.1 material, NACE MR0175, wetted metal parts, inspection certificate	✓	✓	✓	D <sup>1)</sup>
Declaration of Conformity NACE MR0175, wetted metal parts	✓	✓	✓	JB <sup>2)</sup>
Declaration of Conformity NACE MR0175, wetted metal parts	✓	✓	✓	C <sup>1)</sup>
EN10204-3.1 routine test, inspection certificate	✓	✓	✓	3 <sup>1) 3)</sup>
EN10204-3.1 pressure test, inspection certificate	✓	✓	✓	4 <sup>1) 3)</sup>
EN10204-3.1 material wetted parts +Ra, Ra= surface roughness, dimensional check, inspection certificate	–	✓	–	6 <sup>1) 3)</sup>
EN10204-3.1 measurement of delta ferrite content, inspection certificate	–	✓	–	8 <sup>1) 3)</sup>

1) Product Configurator, order code for "Additional options 1"

2) Product Configurator, order code for "Test, certificate"

3) Product Configurator, order code for "Additional options 2"

## Calibration

Description	FMD77	FMD78	PMD75	Option <sup>1)</sup>
Nominal range; mbar/bar	✓	✓	✓	1
Nominal range; kPa/MPa	✓	✓	✓	2
Nominal range; mmH2O/mH2O	✓	✓	✓	3
Nominal range; inH2O/ftH2O	✓	✓	✓	4
Nominal range; psi	✓	✓	✓	6
Configured for Deltatop; see additional specification	–	–	✓	8
Customer-specific; see additional specification	✓	✓	✓	B
Factory calibration certificate, 5-point; see additional specification	✓	✓	✓	C
DKD/DAkkS certificate; see additional specification	✓	✓	✓	D
Customized pressure; see additional specification	✓	✓	✓	E
Customized level; see additional specification	✓	✓	✓	F
Customized flow; see additional specification	–	–	✓	G
Customized pressure + 5-point factory calibration certificate; see additional specification	✓	✓	✓	H
Customized level + 5-point factory calibration certificate; see additional specification	✓	✓	✓	I
Customized flow + 5-point factory calibration certificate; see additional specification	✓	✓	✓	J
Platinum; see additional specification	–	–	✓	K
Platinum + factory calibration certificate 5-point; see additional specification	–	–	✓	L
Platinum + DKD/DAkkS certificate; see additional specification	–	–	✓	M

1) Product Configurator, order code for "Calibration; Unit"

## Ordering information

Detailed ordering information is available from the following sources:

- In the Product Configurator on the Endress+Hauser website: [www.endress.com](http://www.endress.com) → Select country → Products → Select product → Product page function: Configure this product
- From your Endress+Hauser Sales Center: [www.endress.com/worldwide](http://www.endress.com/worldwide)

### Product Configurator - the tool for individual product configuration

- Up-to-the-minute configuration data
  - Depending on the device: Direct input of information specific to measuring point, e.g. measuring range
  - Automatic verification of exclusion criteria
  - Automatic creation of the order code and its breakdown in PDF or Excel output format
  - Ability to order directly from the Endress+Hauser Online Shop

#### Scope of delivery

- Measuring device
- Optional accessories
- Brief Operating Instructions
- Certificates

#### Configuration data sheet

##### Pressure

The following configuration data sheet must be completed and included with the order if the option "E" or "H" has been selected in the Product Configurator, order code for "Calibration; Unit".

Pressure unit				
<input type="checkbox"/> mbar	<input type="checkbox"/> mmH <sub>2</sub> O <sup>1)</sup>	<input type="checkbox"/> mmHg <sup>2)</sup>	<input type="checkbox"/> Pascal	<input type="checkbox"/> torr
<input type="checkbox"/> bar	<input type="checkbox"/> mH <sub>2</sub> O <sup>1)</sup>	<input type="checkbox"/> inHg <sup>2)</sup>	<input type="checkbox"/> hPa	<input type="checkbox"/> g/cm <sup>2</sup>
<input type="checkbox"/> psi	<input type="checkbox"/> ftH <sub>2</sub> O <sup>1)</sup>	<input type="checkbox"/> gf/cm <sup>2</sup>	<input type="checkbox"/> kPa	<input type="checkbox"/> kg/cm <sup>2</sup>
	<input type="checkbox"/> inH <sub>2</sub> O <sup>1)</sup>	<input type="checkbox"/> kgf/cm <sup>2</sup>	<input type="checkbox"/> MPa	<input type="checkbox"/> lb/ft <sup>2</sup>
				<input type="checkbox"/> atm

- 1) The conversion factor of the pressure unit refers to a reference temperature of 4 °C (39.2 °F).
- 2) The conversion factor of the pressure unit refers to a reference temperature of 0 °C (32 °F).

Calibration range / Output		
Lower range value (LRV):	_____	[pressure unit]
Upper range value (URV):	_____	[pressure unit]

Display
Display of the content of the main line (option depends on sensor and communication variant)
<input type="checkbox"/> Primary value [PV] (default)
<input type="checkbox"/> Primary value [%]
<input type="checkbox"/> Pressure
<input type="checkbox"/> Current [mA] (HART only)
<input type="checkbox"/> Temperature
<input type="checkbox"/> Error number
<input type="checkbox"/> Alternating display

Damping
Damping: _____ sec (Default 2 sec)

Smallest span (factory calibration)

**Level**

The following configuration data sheet must be completed and included with the order if the option "F" or "T" has been selected in the Product Configurator, order code for "Calibration; Unit".

Pressure unit				Output unit (scaled unit)					
<input type="checkbox"/> mbar	<input type="checkbox"/> mmH <sub>2</sub> O <sup>1)</sup>	<input type="checkbox"/> mmHg <sup>2)</sup>	<input type="checkbox"/> Pascal	<input type="checkbox"/> torr	Mass	Lengths	Volume	Volume	Percent
<input type="checkbox"/> bar	<input type="checkbox"/> mH <sub>2</sub> O <sup>1)</sup>	<input type="checkbox"/> inHg <sup>2)</sup>	<input type="checkbox"/> hPa	<input type="checkbox"/> g/cm <sup>2</sup>	<input type="checkbox"/> kg	<input type="checkbox"/> m	<input type="checkbox"/> l	<input type="checkbox"/> USgal	<input type="checkbox"/> %
<input type="checkbox"/> psi	<input type="checkbox"/> ftH <sub>2</sub> O <sup>1)</sup>	<input type="checkbox"/> gf/cm <sup>2</sup>	<input type="checkbox"/> kPa	<input type="checkbox"/> kg/cm <sup>2</sup>	<input type="checkbox"/> t	<input type="checkbox"/> dm	<input type="checkbox"/> hl	<input type="checkbox"/> impgal	
	<input type="checkbox"/> inH <sub>2</sub> O <sup>1)</sup>	<input type="checkbox"/> kgf/cm <sup>2</sup>	<input type="checkbox"/> MPa	<input type="checkbox"/> lb/ft <sup>2</sup>	<input type="checkbox"/> lb	<input type="checkbox"/> cm	<input type="checkbox"/> m <sup>3</sup>	<input type="checkbox"/> USbbiPE	
				<input type="checkbox"/> atm		<input type="checkbox"/> mm	<input type="checkbox"/> ft <sup>3</sup>	TR	
						<input type="checkbox"/> ft			
						<input type="checkbox"/> inch			
Empty calibration [a]: Low pressure value (empty) _____ [pressure unit]				Empty calibration [a]: Low measured value (empty) _____ [Scaled unit]					
Full calibration [b]: High pressure value (full) _____ [pressure unit]				Full calibration [b]: High level value (full) _____ [Scaled unit]					

**Example**

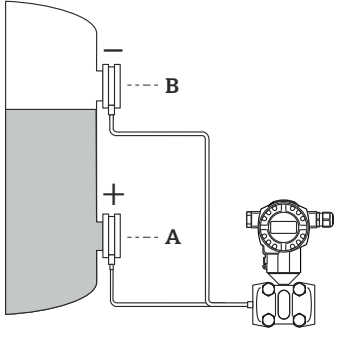

A0023985

A 500 mbar (7.25 psi) / 100 m<sup>3</sup>  
 B 50 mbar (1 psi) / 3 m<sup>3</sup>

- 1) The conversion factor of the pressure unit refers to a reference temperature of 4 °C (39.2 °F).
- 2) The conversion factor of the pressure unit refers to a reference temperature of 0 °C (32 °F).

Display
Display of the content of the main line (option depends on sensor and communication variant)
<input type="checkbox"/> Primary value [PV] (default) <input type="checkbox"/> Primary value [%] <input type="checkbox"/> Pressure <input type="checkbox"/> Current [mA] (HART only) <input type="checkbox"/> Temperature <input type="checkbox"/> Level before lin. <input type="checkbox"/> Tank content <input type="checkbox"/> Error number <input type="checkbox"/> Alternating display

Damping
Damping: _____ sec (Default 2 sec)



## Accessories

---

**HistoROM®/M-DAT**

HistoROM®/M-DAT is a memory module which can be attached to every electronic insert.

Ordering information:

Product Configurator, order code for "Additional options 1" or "Additional options 2", version "N" or as a separate accessory (part no.: 52027785).

---

**Welding flanges and welding neck**

For details refer to TI00426F/00/EN "Weld-in adapter and flanges".

## Supplementary documentation

<b>Field of Activities</b>	Pressure measurement, powerful instruments for process pressure, differential pressure, level and flow: FA00004P/00/EN
----------------------------	---

<b>Technical Information</b>	<ul style="list-style-type: none"> <li>■ EMC test procedures: TI00241F/00/EN</li> <li>■ Cerabar S: TI00383P/00/EN</li> <li>■ Deltapilot S: TI00416P/00/EN</li> <li>■ Deltatop: <ul style="list-style-type: none"> <li>– Orifice plate: TI00422P/00/EN</li> <li>– Pitot tube: TI00425P/00/EN</li> <li>–</li> </ul> </li> <li>■ EMC test procedures: TI00241F/00/EN</li> </ul>
------------------------------	--

<b>Operating Instructions</b>	<p>4 to 20 mA HART:</p> <ul style="list-style-type: none"> <li>■ Deltabar S: BA00270P/00/EN</li> <li>■ Description of device functions Cerabar S/Deltabar S/Deltapilot S: BA00274P/00/EN</li> </ul> <p>PROFIBUS PA:</p> <ul style="list-style-type: none"> <li>■ Deltabar S: BA00294P/00/EN</li> <li>■ Description of device functions Cerabar S/Deltabar S/Deltapilot S: BA00296P/00/EN</li> </ul> <p>FOUNDATION Fieldbus:</p> <ul style="list-style-type: none"> <li>■ Deltabar S: BA00301P/00/EN</li> <li>■ Description of device functions Cerabar S/Deltabar S/Deltapilot S: BA00303P/00/EN</li> </ul>
-------------------------------	---

<b>Brief Operating Instructions</b>	<ul style="list-style-type: none"> <li>■ 4 to 20 mA HART, Deltabar S: KA01018P/00/EN</li> <li>■ PROFIBUS PA, Deltabar S: KA01021P/00/EN</li> <li>■ FOUNDATION Fieldbus, Deltabar S: KA01024P/00/EN</li> </ul>
-------------------------------------	---

<b>Functional safety manual (SIL)</b>	Deltabar S (4 to 20 mA): SD00189P/00/EN
---------------------------------------	---

<b>Overfill protection</b>	WHG: ZE00259P/00/DE
----------------------------	---------------------

<b>Safety Instructions (XA)</b>	Depending on the approval, the following Safety Instructions (XA) are supplied with the device. They are an integral part of the Operating Instructions.
---------------------------------	--

Directive	Electronic insert	Documentation	Option <sup>1)</sup>
ATEX II 1/2G Ex ia IIC T6 (WHG)	4 to 20 mA HART, PROFIBUS PA, FOUNDATION Fieldbus	XA00235P	1 (6)
ATEX II 1/2D Ex tD	4 to 20 mA HART	XA00237P	2
	PROFIBUS PA, FOUNDATION Fieldbus	XA00280P	
ATEX II 1/3D Ex tD	4 to 20 mA HART	XA00239P	4
	PROFIBUS PA, FOUNDATION Fieldbus	XA00282P	
ATEX II 2 G Ex d IIC T6 Gb	4 to 20 mA HART, PROFIBUS PA, FOUNDATION Fieldbus	XA00240P	5
ATEX II 3 G Ex na II T6	4 to 20 mA HART, PROFIBUS PA, FOUNDATION Fieldbus	XA00241P	7
ATEX II 1/2G Ex ia + II 1/2D Ex iaD	4 to 20 mA HART, PROFIBUS PA, FOUNDATION Fieldbus	XA00243P	3
ATEX II 1G Ex ia + II 1D Ex iaD	4 to 20 mA HART, PROFIBUS PA, FOUNDATION Fieldbus	XA00275P	8
ATEX II 1/2G Ex ia IIC T6+II 2G Ex d IIC T6	4 to 20 mA HART, PROFIBUS PA, FOUNDATION Fieldbus	XA00242P	B
ATEX II Ex ia/Ex d + FM/CSA IS + XP ATEX II 1/2G Ex ia IIC T6+ ATEX II 2G Ex d IIC T6+FM/CSA IS + XP Cl.II Div.1 Gr.A-G/B-GFM/CSA: Zone 1,2	4 to 20 mA HART	XA00242P ZD00153P XA01196P	F
	PROFIBUS PA, FOUNDATION Fieldbus	XA00242P XA01198P ZD00191P	
IECEx Zone 0/1 Ex ia IIC T6	4 to 20 mA HART, PROFIBUS PA, FOUNDATION Fieldbus	XB00004P	I

Directive	Electronic insert	Documentation	Option <sup>1)</sup>
IEC Ex d IIC T6 Gb	4 to 20 mA HART, PROFIBUS PA, FOUNDATION Fieldbus	XA00512P	M
NEPSI Ex ia IIC T6	4 to 20 mA HART, PROFIBUS PA, FOUNDATION Fieldbus	XA00550P	H
NEPSI Ex d IIC T6	4 to 20 mA HART, PROFIBUS PA, FOUNDATION Fieldbus	XA00552P	G

1) Product Configurator, order code for "Approval"

Directive	Electronic insert	Documentation	Option <sup>1)</sup>
TIIS Ex do IIC T6	4 to 20 mA HART	TC18007 TC18008	L

1) Product Configurator, order code for "Approval"

Directive	Electronic insert	Documentation	Option <sup>1)</sup>
INMETRO Ex ia IIC T6 Ga/Gb	4 to 20 mA HART, PROFIBUS PA, FOUNDATION Fieldbus	XA01318P	J
INMETRO Ex d IIC T6 Gb	4 to 20 mA HART, PROFIBUS PA, FOUNDATION Fieldbus	XA01281P	O
INMETRO Ex ta IIIC Da/Db	4 to 20 mA HART, PROFIBUS PA, FOUNDATION Fieldbus	XA01316P	Z

1) Product Configurator, order code for "Approval"

## Installation/Control

### Drawings

Directive	Electronic insert	Documentation	Option <sup>1)</sup>
FM IS Cl.I,II,III Div.1 Gr.A-G, NI Cl.I Div.2 Gr.A-D, AEx ia, Zone 0,1,2,20,21,22	4 to 20 mA HART	XA01058P	S
	PROFIBUS PA, FOUNDATION Fieldbus	XA01060P	
FM/CSA IS + XP Cl.I Div.1 Gr.A-D, FM/CSA: Zone 1,2	4 to 20 mA HART	XA00591P XA01196P	Q
	PROFIBUS PA, FOUNDATION Fieldbus	XA00590P XA01198P	
FM DIP Cl.II,III Div.1 Gr.E-G, Zone 21,22	4 to 20 mA HART, PROFIBUS PA, FOUNDATION Fieldbus	FM3017778	Q
CSA C/US IS Cl.I,II,III Div.1 Gr.A-G, Cl.I Div.2 Gr.A-D, Ex ia, C: Zone 0,1,2/ US: Zone 0,1,2,20,21,22	4 to 20 mA HART	ZD00142P	U
	PROFIBUS PA, FOUNDATION Fieldbus	ZD00189P	
FM IS + XP Cl.I Div.1 Gr.A-D, Zone 1,2	4 to 20 mA HART	XA01196P	C
	PROFIBUS PA, FOUNDATION Fieldbus	XA01198P	
FM NI Cl.I Div.2 Gr.A-D, Zone 2	4 to 20 mA HART, PROFIBUS PA, FOUNDATION Fieldbus	XA01064P	R
FM XP Cl.I Div.1 Gr.A-D, AEx d, Zone 1,2	4 to 20 mA HART, PROFIBUS PA, FOUNDATION Fieldbus	XA01071P	T
CSA C/US IS + XP Cl.I Div.1 Gr.A-D, Zone 1,2	4 to 20 mA HART	ZD00153P	D
	PROFIBUS PA, FOUNDATION Fieldbus	ZD00191P	
ATEX II Ex ia/Ex d + FM/CSA IS + XP ATEX II 1/2G Ex ia IIC T6+ ATEX II 2G Ex d IIC T6+FM/CSA IS + XP Cl.I,II Div.1 Gr.A-G/B-GFM/CSA: Zone 1,2	4 to 20 mA HART	XA00242P ZD00153P XA01196P	F
	PROFIBUS PA, FOUNDATION Fieldbus	XA00242P XA01198P ZD00191P	
CSA C/US XP Cl.I Div.1 Gr.B-D, Ex d, Zone 1,2	4 to 20 mA HART, PROFIBUS PA, FOUNDATION Fieldbus	ZD00229P	V
CSA C/US Cl.II, III Div.1 Gr.E-G	4 to 20 mA HART, PROFIBUS PA, FOUNDATION Fieldbus	CSA1509834	W
CSA C/US General Purpose	4 to 20 mA HART, PROFIBUS PA, FOUNDATION Fieldbus	-	Z

1) Product Configurator, order code for "Approval"

## Registered trademarks

<b>HART®</b>	Registered trademark of the HART Communication Foundation, Austin, USA
<b>PROFIBUS®</b>	Registered trademark of the PROFIBUS User Organization, Karlsruhe, Germany
<b>FOUNDATION™ Fieldbus</b>	Registered trademark of the Fieldbus Foundation, Austin, Texas, USA

## Patents

This product is protected by at least one of the following patents. Further patents are pending.

DE patents	US patents	EP patents
DE 203 11 320 U1	-	-
-	US 6,631,644 A1	EP 1 299 701 B1
-	US 5,670,063 A1	EP 0 516 579 B1
-	US 5,539,611 A1	-
-	US 5,050,034 A1	EP 0 445 382 B1
-	US 5,097,712 A1	EP 0 420 105 B1
-	US 5,050,035 A1	EP 0 414 871 B1
-	US 5,005,421 A1	EP 0 351 701 B1
-	-	EP 0 414 871 B1
-	US 5,334,344 A1	EP 0 490 807 B1
-	US 6,703,943 A1	-
-	US 5,499,539 A1	EP 0 613 552 B1



[www.addresses.endress.com](http://www.addresses.endress.com)

---